

155M SFP BIDI 40km Single-Mode Optical Transceiver

Features

- Up to 155Mb/s data links
- 1310nm FP laser transmitter and PIN photo-detector
- Up to 40km on 9/125µm SMF
- Hot-pluggable SFP footprint
- BIDI LC/UPC type pluggable optical interface
- Low power dissipation
- Metal enclosure, for lower EMI
- RoHS-10 compliant and lead-free
- Support Digital Diagnostic Monitoring interface
- Single +3.3V power supply
- Power dissipation: <0.86W
- RoHs compliant and lead-free
- Compliant with SFF-8472 V9.5

Applications

- Switch to Switch interface
- Switched Backplane Applications
- Fast Ethernet
- Other optical transmission systems

Compliance

- SFP MSA(INF-8074i)
- SFF-8472 V9.5
- ITUT-G.957 STM-1

Description

The SFP-FE-U40-35 Small Form Factor Pluggable (SFP) transceivers are compatible with the Small Form Factor Pluggable Multi-Sourcing Agreement (MSA). The transceiver consists of five sections: the LD driver, the limiting amplifier, the digital diagnostic monitor, the FP laser and the PIN photo-detector. The module data link up to 40km in 9/125 μ m single mode fiber.

The optical output can be disabled by a TTL logic high-level input of Tx Disable, and the system also can disable the module via I2C. Tx Fault is provided to indicate that degradation of the laser. Loss of signal (LOS) output is provided to indicate the loss of an input optical signal of receiver or the link status with partner. The system can also get the LOS (or Link)/Disable/Fault information via I2C register access.

Absolute Maximum Ratings

Table1-Absolute Maximum Ratings						
Parameter	Symbols	Min.	Typical	Max.	Unit	Notes
Storage Temperature	T _s	-40		+85	°C	
Storage Ambient Humidity	HA	+5		+95	%	
Power Supply Voltage	VCC	-0.3		+3.6	V	
Signal Input Voltage		-0.3		V _{cc} +0.3	V	
Receiver Damage Threshold		5			dBm	

Recommended Operating Conditions

Table2-Recommended Operating Conditions							
Parameter	Symbols	Min.	Typical	Max.	Unit	Notes	
Operating Case temperature	T _c	0		+70	°C		
Power Supply Voltage	V _{cc}	3.135	3.3	3.465	V		
Data Rate			155		Mbps		
Control Input Voltage High		2		V _{cc}	V		
Control Input Voltage Low		0		0.8	V		
Transmission Distance			40		KM		
Coupled Fiber		Single mode fiber					9/125 μ m SMF

Electrical Characteristic

Table3-Electrical Characteristic						
Parameter	Symbol	Min.	Typ.	Max.	Unit	Notes
Power Consumption	p			0.86	W	
Supply Current	I _{cc}			260	mW	
Transmitter						

Single-ended Input Voltage Tolerance	V _{cc}	-0.3		4.0	V	
Differential Input Voltage Swing	V _{in, pp}	200		2400	mV _{pp}	
Differential Input Impedance	Z _{in}	90	100	110	Ohm	
Transmit Disable Assert Time				5	us	
Transmit Disable Voltage	V _{dis}	V _{ee} -1.3		V _{cc}	V	
Transmit Enable Voltage	V _{en}	V _{ee} -0.3		0.8	V	
Receiver						
Differential Output Voltage Swing	V _{out,pp}	500		900	mV _{pp}	
Differential Output Impedance	Z _{out}	90	100	110	Ohm	
Data output rise/fall time	T _r /T _f		100		ps	20% to 80%
LOS Assert Voltage	V _{losH}	V _{cc} -1.3		V _{cc}	V	
LOS De-assert Voltage	V _{losL}	V _{cc} -0.3		0.8	V	

Optical Characteristics

Table4-Optical Characteristics						
Parameter	Symbols	Min.	Typ.	Max.	Unit	Notes
Transmitter						
Center Wavelength	λ_c	1260	1310	1360	nm	
Spectrum Bandwidth(RMS)	σ			3.5	nm	
Average Optical Power	P _{AVG}	-7		-2	dBm	1
Extinction Ratio	ER	8.2			dB	
Transmitter OFF Output Power	P _{off}			-45	dBm	
Transmitter Eye Mask Definition	Compliant with G.957(class 1 laser safety)					
Receiver						
Center Wavelength	λ_c	1530	1550	1570	nm	
Sensitivity (Average Power)	Sen.			-32	dBm	2
Input Saturation Power(overload)	P _{sat}	-10			dBm	
LOS Assert	LOSA	-44			dBm	3
LOS De-assert	LOSD			-33	dBm	3
LOS Hysteresis	LOSH	0.5	2	6	dB	

Notes:

[1] Measure at 2²³-1 NRZ PRBS pattern

[2] Measured with Light source 1310nm, ER=8.2dB; BER = < 10⁻¹² @PRBS=2²³-1 NRZ

[3] When LOS de-asserted, the RX data+/- output is High-level (fixed).

Pin Description

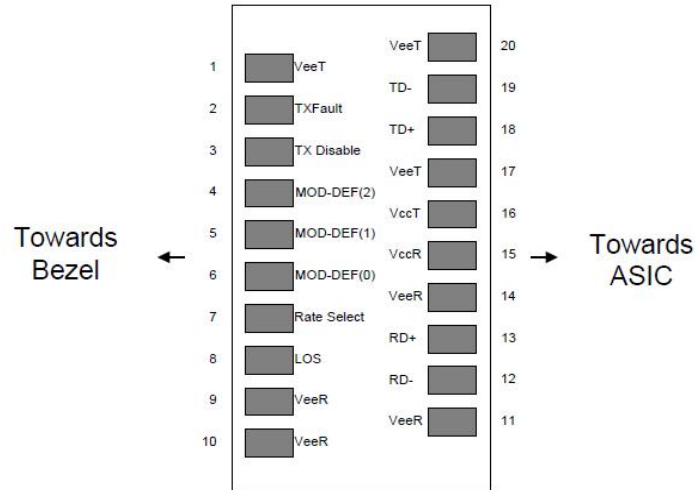

Figure1 Pin view

Pin Function Definitions

Pin	Name	Description	Notes
1	V _{EET}	Transmitter Ground (Common with Receiver Ground)	1
2	T _{FAULT}	Transmitter Fault.Open Drain. Logic "0" indicates normal operation.	2
3	T _{DIS}	Transmitter Disable. Laser output disabled on high or open.	3
4	MOD_DEF(2)	Module Definition 2. Data line for Serial ID.	3
5	MOD_DEF(1)	Module Definition 1. Clock line for Serial ID.	3
6	MOD_DEF(0)	Module Definition 0. Grounded within the module.	4
7	Rate Select	No connection required.	5
8	LOS	Loss of Signal indication. Open Drain. Logic "0" indicates normal operation.	4
9	V _{EER}	Receiver Ground (Common with Transmitter Ground)	1
10	V _{EER}	Receiver Ground (Common with Transmitter Ground)	1
11	V _{EER}	Receiver Ground (Common with Transmitter Ground)	1
12	RD-	Receiver Inverted DATA out(CML). AC Coupled	
13	RD+	Receiver Non-inverted DATA out(CML). AC Coupled	
14	V _{EER}	Receiver Ground (Common with Transmitter Ground)	1
15	V _{CCR}	Receiver Power Supply	
16	V _{CCT}	Transmitter Power Supply	
17	V _{EET}	Transmitter Ground (Common with Receiver Ground)	1
18	TD+	Transmitter Non-Inverted DATA in. AC Coupled.	
19	TD-	Transmitter Inverted DATA in. AC Coupled.	
20	V _{EET}	Transmitter Ground (Common with Receiver Ground)	1

Notes:

[1] Circuit ground is internally isolated from chassis ground.

[2] Laser output disabled on TDIS>2.0V or open, enabled on TDIS<0.8V.

[3] Should be pulled up with 4.7k - 10kohms on host board to a voltage between 2.0V and 3.6V MOD_DEF(0) pulls line low to indicate module is plugged in.

[4] This is an optional input used to control the receiver bandwidth for compatibility with multiple data rates (most likely Fiber Channel 1x and 2x Rates). If implemented, the input will be internally pulled down with >30kΩ resistor. The input states are:

Low (0 - 0.8V): Reduced Bandwidth

(>0.8V, <2.0V): Undefined

High (2.0 - 3.465V): Full Bandwidth

Open: Reduced Bandwidth

[5] LOS is open collector output. Should be pulled up with 4.7k - 10kohms on host board to a voltage between 2.0V and 3.6V. Logic 0 indicates normal operation; logic 1 indicates loss of signal.

Digital Diagnostic Functions

The following digital diagnostic characteristics are defined over the Recommended Operating Environment unless otherwise specified. It is compliant to SFF-8472 Rev10.2 with internal calibration mode. For external calibration mode please contact our sales staff.

Table6-Digital Diagnostic Functions					
Parameter	Symbol	Min.	Max.	Unit	Notes
Temperature monitor absolute error	DMI_Temp	-3	3	degC	Over operating temp
Supply voltage monitor absolute error	DMI_VCC	-0.15	0.15	V	Full operating range
RX power monitor absolute error	DMI_RX	-3	3	dB	
Bias current monitor	DMI_bias	-10%	10%	mA	
TX power monitor absolute error	DMI_TX	-3	3	dB	

Mechanical Dimensions

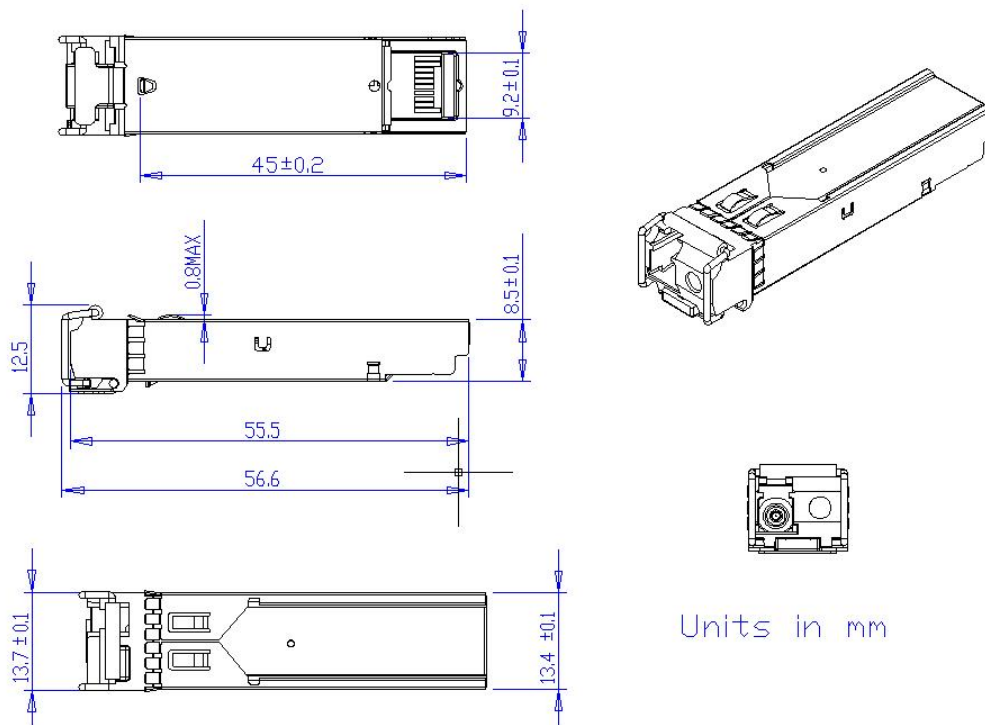

Figure2 Mechanical Outline

Precautions

- This device is susceptible to damage as a result of electrostatic discharge (ESD). A static free environment is highly recommended. Follow guidelines according to proper ESD procedures.
- Radiation emitted by laser devices can be dangerous to human eyes. Avoid eye exposure to direct or indirect radiation.

Caution

All adjustments have been done at the factory before the shipment of the devices. No maintenance and user serviceable part is required. Tampering with and modifying the performance of the device will result in voided product warranty.

Contact Information

Naddod Networking Technology Co.,Ltd.

Address: 302, Building F1, Optics Valley Software Park, Guanshan 1st Road
East Lake High-tech Zone, Wuhan ,P.R.China

Tel:4000698860

Tel:027-59728168

Email:marketing@naddod.com

Website: www.naddod.com