

200Gb/s QSFP56 Active Optical Cable

Features

- Up to 200Gb/s data rate
- 4x 50Gb/s PAM4 modulation
- SFF-8665 compliant QSFP56 port
- SFF-8636 compliant I2C management
- Single 3.3V power supply
- 4.5W power dissipation each end, with re-timing
- Operating case temp Commercial: 0°C to +70 °C
- Hot pluggable
- RoHS compliant

Applications

- Other optical links

Absolute Maximum Ratings

Parameter	Symbol	Min.	Typical	Max.	Unit	Note
Supply Voltage	V _{CC3}	-0.5	-	+3.6	V	
Storage Temperature	T _S	-5	-	+70	°C	
Operating Humidity	RH	+5	-	+85	%	1

Note:

[1] No condensation

Recommended Operating Conditions

Parameter	Symbol	Min.	Typical	Max.	Unit	Note
Operating Case Temperature	T _C	0	-	+70	°C	
Power Supply Voltage	V _{CC}	3.14	3.3	3.47	V	
Power Dissipation	P _d	-	-	4.5	W	1

Note:

[1] Per terminal

Characteristics

Parameter	Symbol	Unit	Min.	Typical	Max.	Note
Transmitter						
Signaling rate (each lane)	SR	GBd	26.5625 ± 100 ppm			
Differential data input voltage per lane	V _{in,pp,dif} f	mV	900	-	-	
Differential termination mismatched	-	%	-	-	10	
Single-ended voltage tolerance range	-	V	-0.4	-	3.3	
DC common mode voltage	-	mV	-350	10	2850	
Receiver						
Signaling rate (each lane)	SR	GBd	26.5625 ± 100 ppm			
Differential output voltage	-	mV	-	-	900	
Differential termination mismatch	-	%	-	-	10	
Transition time (min, 20% to 80%)	-	ps	9.5	-	-	
DC common mode voltage	-	mV	-350	-	2850	
Bit Error Ratio	BER	-	-	-	2.4E-4	Note1

Note:

[1] PRBS31Q@26.5625Gbd PAM4

Recommended Interface

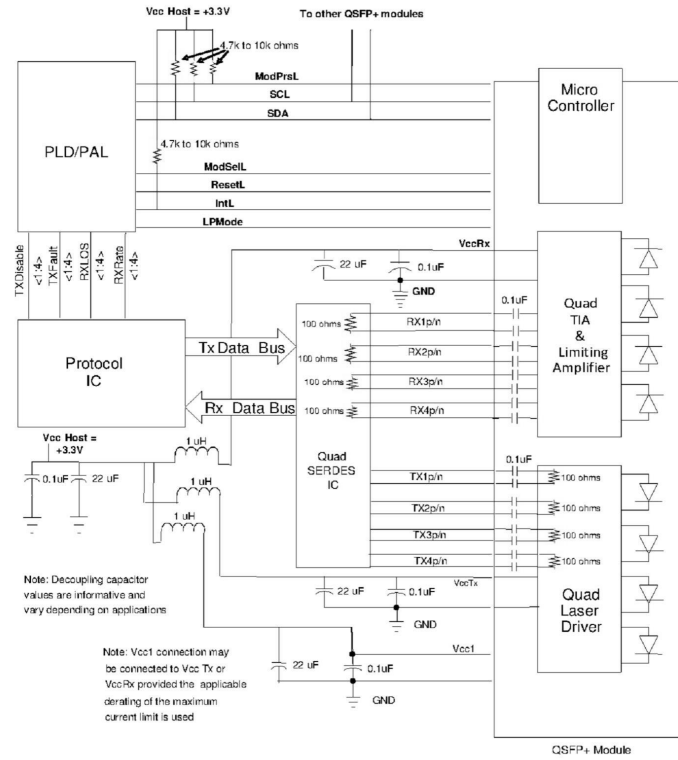

Figure 1 Recommended Interface Circuit

Pin arrangement

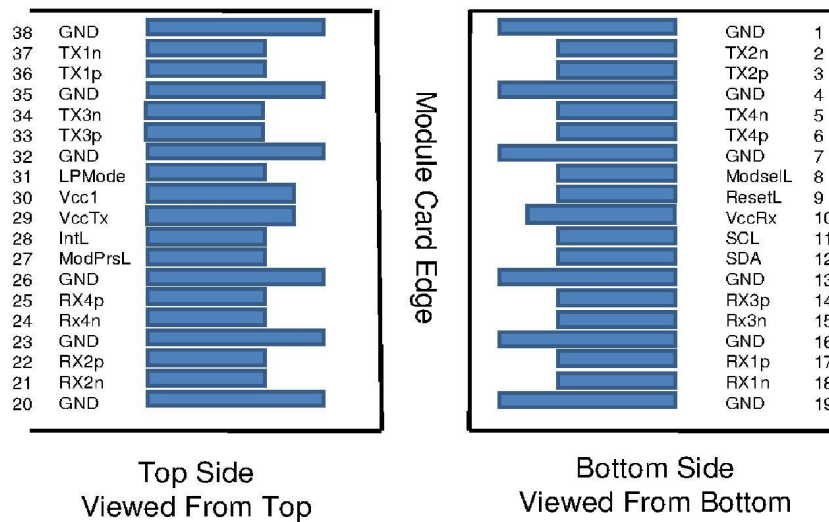

Figure 2 Pin View

Pin Descriptions

Pin	Logic	Symbol	Description	Note
1	G	GND	Ground	1
2	S	Tx2n	Transmitter Inverted Data Input	
3	S	Tx2p	Transmitter Non-Inverted Data Input	
4	G	GND	Ground	1
5	S	Tx4n	Transmitter Inverted Data Input	
6	S	Tx4p	Transmitter Non-Inverted Data Input	
7	G	GND	Ground	1
8	IO	ModSelL	Module Select	
9	IO	ResetL	Module Reset	
10	Power	Vcc Rx	+3.3V Power Supply Receiver	
11	IO	SCL	2-wire serial interface clock	
12	IO	SDA	2-wire serial interface data	
13	G	GND	Ground	1
14	S	Rx3p	Receiver Non-Inverted Data Output	
15	S	Rx3n	Receiver Inverted Data Output	
16	G	GND	Ground	1
17	S	Rx1p	Receiver Non-Inverted Data Output	
18	S	Rx1n	Receiver Inverted Data Output	
19	G	GND	Ground	1
20	G	GND	Ground	1
21	S	Rx2n	Receiver Inverted Data Output	
22	S	Rx2p	Receiver Non-Inverted Data Output	
23	G	GND	Ground	1
24	S	Rx4n	Receiver Inverted Data Output	
25	S	Rx4p	Receiver Non-Inverted Data Output	
26	G	GND	Ground	
27	IO	ModPrsL	Module Present	
28	IO	IntL	Interrupt	
29	Power	Vcc Tx	+3.3V Power supply transmitter	
30	Power	Vcc1	+3.3V Power supply	
31	IO	LPMODE	Low Power Mode	

32	G	GND	Ground	1
33	S	Tx3p	Transmitter Non-Inverted Data Input	
34	S	Tx3n	Transmitter Inverted Data Input	
35	G	GND	Ground	1
36	S	Tx1p	Transmitter Non-Inverted Data Input	
37	S	Tx1n	Transmitter Inverted Data Input	
38	G	GND	Ground	1

Monitoring Specification

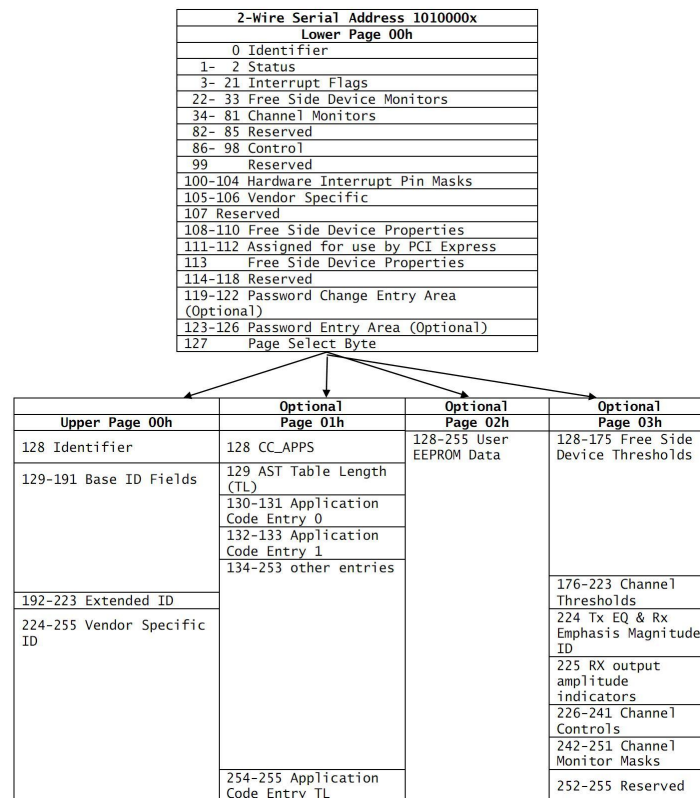

Figure 3 Monitoring Specification

Mechanical

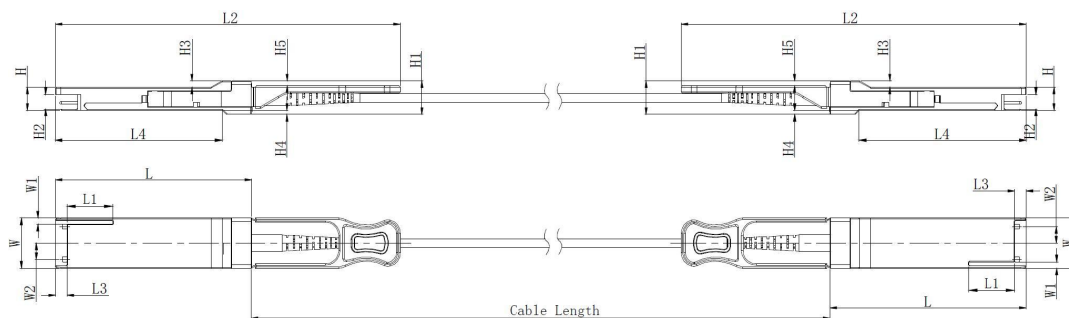

Figure 4 Mechanical Diagram

Unit mm

	L	L1	L2	L3	L4	W	W1	W2	H	H1	H2	H3	H4	H5
Max	72.2	-	128	4.35	61.4	18.45	-	6.2	8.6	12.4	5.35	2.5	1.6	2.0
Type	72.0	-	-	4.20	61.2	18.35	-	-	8.5	12.2	5.2	2.3	1.5	1.8
Min	68.8	16.5	124	4.05	61.0	18.25	2.2	5.8	8.4	12.0	5.05	2.1	1.3	1.6

Regulatory Compliance

Parameter	Value	Units
Diameter	3±0.2	mm
Minimum bend radius	30	mm
Length tolerance	1 m ≤ length ≤ 4.5 m: +15 / -0	cm
	5 m ≤ length ≤ 14.5 m: +30 / -0	cm
	Length ≤ 15.0 m: +2% / -0	m
Cable color	Aqua	

Warnings

Handling Precautions: This device is susceptible to damage as a result of electrostatic discharge (ESD). A static free environment is highly recommended. Follow guidelines according to proper ESD procedures.

Laser Safety: Radiation emitted by laser devices can be dangerous to human eyes. Avoid eye exposure to direct or indirect radiation.

Further Information:

Web www.naddod.com

Email For order requirements: sales@naddod.com

For cooperation: agency@naddod.com

For customer service: support@naddod.com

For other informations: info@naddod.com

For technical support: tech@naddod.com

Disclaimer

1. We are committed to continuous product improvement and feature upgrades, and the contents contained in this manual are subject to change without notice.

2. Nothing herein should be construed as constituting an additional warranty.

3. NADDOD assumes no responsibility for the use or reliability of equipment or software not provided by NADDOD.

Copyright © NADDOD.COM All Rights Reserved, 2022