

# 400G QSFP-DD Direct Attach Passive Copper Cable

## Features

- Compliant with QSFP-DD MSA Specification Rev 3.4
- SFF-8679 electrical interface compliant
- SFF-8636 management interface support
- Support 50G (PAM4) electrical data rates / channel
- I2C for EEPROM communication, pull to Release latch design
- Excellent EMI/EMC performance 360 degree cable shield termination
- Advantage dual side per-solder automated assembly technologies
- Low loss, stronger mechanical features, more flexible
- QSFP-DD modules will be backwards compatible, allowing them to support existing QSFP modules and provide flexibility for end users and system designers

## Applications

- Data Center & Networking Equipment
- Servers/Storage Devices
- High Performance Computing (HPC)
- Switches/Routers

---

## Standards Compliance

- IEEE802.3Bj, By, IEEE802.3CD
- RoHS Compliant

## Description

In an effort to keep up with the demands of higher performance and increasing amounts of memory bus bandwidth, designers are working to revise, extend and update the solution. 400G QSFP-DD passive cable assembly can provide new generation performance of QSFP by higher data transfer rate. At the same time, QSFP-DD TO 2 QSFP56 cable choose dual side drain cable and self-designed PCBA, provide low loss, less skew and better NEXT. 360 degree EMI crimping shielding and Zinc Die-cast shell designing make the product high-performance. And all the designing is based on the industry standard specifications, such as SFF-8679, SFF-8636 and QSFP-DD TO 2 QSFP56 MSA specification rev 4.0.

## Schematic

WIRING TABLE---QSFP-DD TO QSFP-DD

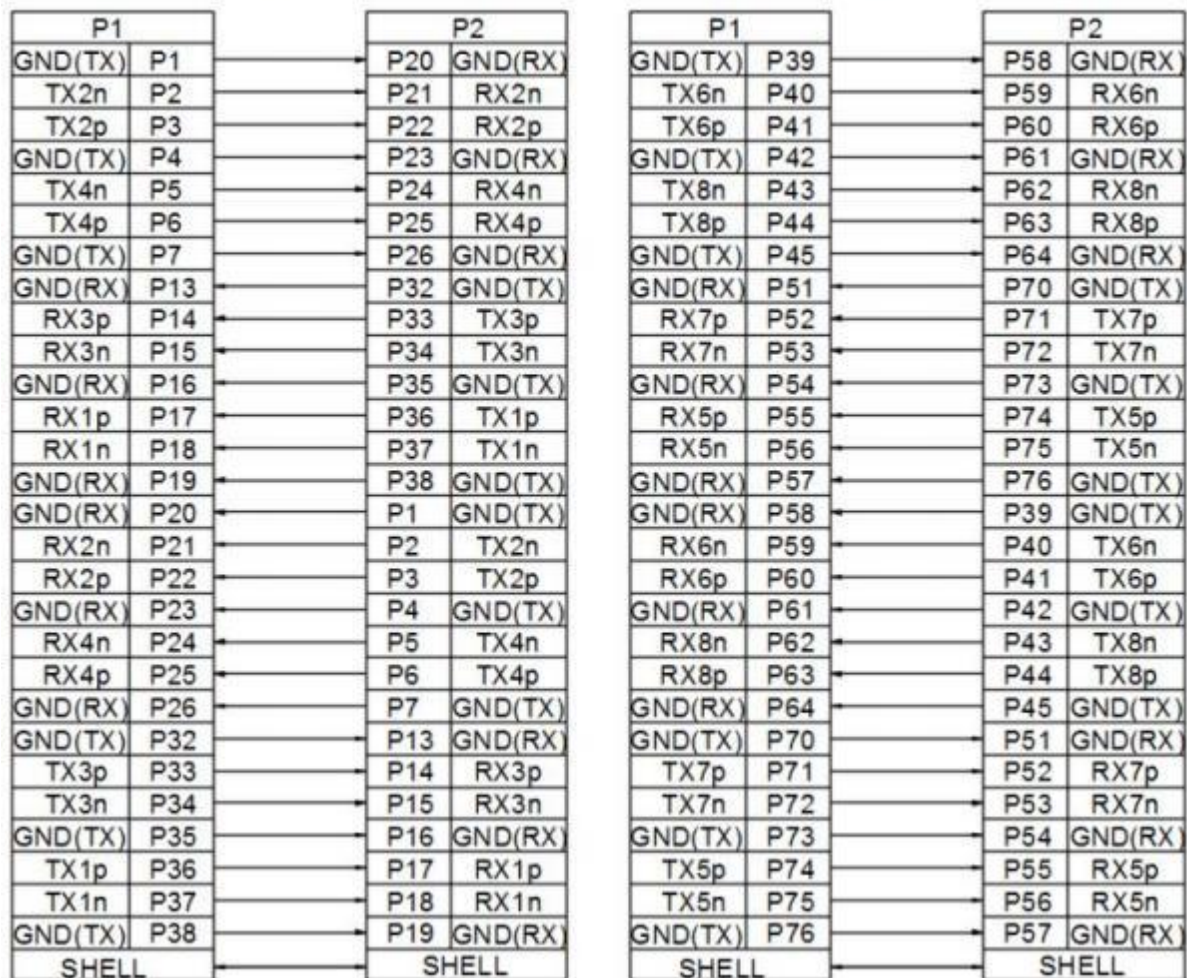

## Mechanical Structure Characteristics Of Plug

1. Raw Cable -- Support 28~30AWG, 100ohm, Silver plated, vw-1, RoHS2.0.
2. PCB – High Speed Very low loss material M6,8 Layers Design; Gold finger plated gold 30u" min., nickel plated 150~700u"; pad: immersion gold 1u" min., nickel plated 100u"min. 94v-0, RoHS2.0;
3. Upper shell -- Zinc Die-cast, with Cu plated 280u" min. overall and Ni plated 120u" min.
4. Bottom shell -- Zinc Die-cast, with Cu plated 280u" min. overall and Ni plated 120u" min.
5. Latch-- Stainless steel ,SUS304 + PA66 CM3004,black;
6. Spring -- Stainless steel ,SUS301EH;
7. Rivet -- Stainless Steel, SUS304;
8. SR (Strain Relief) -- PVC, 45P, BLACK, RoHS2.0.
9. Dust Cover— PVC, 60P, Blue, ANTI-STATIC, RoHS2.0.

## Electrical Design

The electrical design of the QSFP-DD cable assembly is fully compliant to QSFP-DD Hardware Rev4.0 specifications. The electrical design included: a low loss design printed circuit board, DC block capacitances in the Rx channel, and EEPROM chips for the management. Pin layout and function definition are shown in Figure 4 and Table 2.

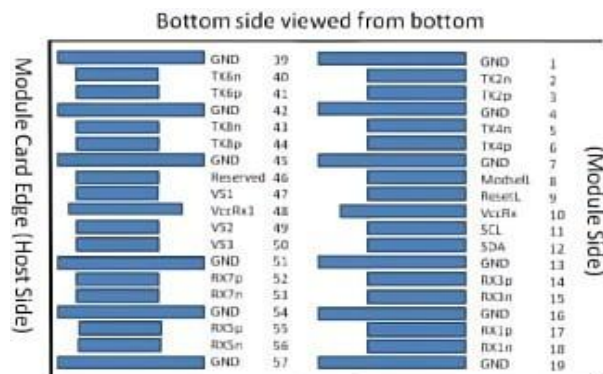

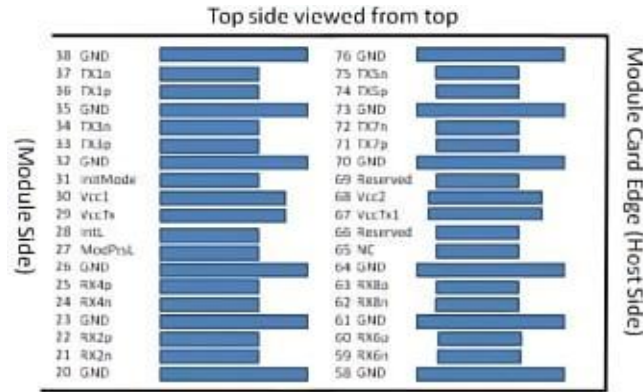

## Pin Descriptions

Table1-Pin Description

Pin	Logic	Symbol	Description	Notes
1		GND	Ground	
2	CML-I	Tx2n	Transmitter Inverted Data Input	
3	CML-I	Tx2p	Transmitter Non-Inverted Data Input	
4		GND	Ground	1
5	CML-I	Tx4n	Transmitter Inverted Data Input	
6	CML-I	Tx4p	Transmitter Non-Inverted Data Input	
7		GND	Ground	1
8	LVTTL-I	ModSelL	Module Select	
9	LVTTL-I	ResetL	Module Reset	
10		Vcc Rx	+3.3V Power Supply Receiver	2
11	LVCMOS-I/O	SCL	2-wire serial interface clock	
12	LVCMOS-I/O	SDA	2-wire serial interface data	
13		GND	Ground	1
14	CML-O	Rx3p	Receiver Non-Inverted Data Output	
15	CML-O	Rx3n	Receiver Inverted Data Output	
16		GND	Ground	1
17	CML-O	Rx1p	Receiver Non-Inverted Data Output	
18	CML-O	Rx1n	Receiver Inverted Data Output	
19		GND	Ground	1
20		GND	Ground	
21	CML-O	Rx2n	Receiver Inverted Data Output	
22	CML-O	Rx2p	Receiver Non-Inverted Data Output	1
23		GND	Ground	

24	CML-0	Rx4n	Receiver Inverted Data Output	
25	CML-0	Rx4p	Receiver Non-Inverted Data Output	1
26		GND	Ground	
27	LVTTTL-0	ModPrsL	Module Present	
28	LVTTTL-0	IntL/RxLOSL	Interrupt. Optionally configurable as RxLOSL via the management interface (SFF-8636)	2
29		VccTx	+3.3V Power supply transmitter	2
30		Vcc1	+3.3V Power supply	
31	LVTTTL-I	InitMode	Initialization mode; In legacy QSFP applications, the InitMode pad is called LPMODE	1
32		GND	Ground	
33	CML-I	Tx3p	Transmitter Non-Inverted Data Input	
34	CML-I	Tx3n	Transmitter Inverted Data Input	1
35		GND	Ground	
36	CML-I	Tx1p	Transmitter Non-Inverted Data Input	
37	CML-I	Tx1n	Transmitter Inverted Data Input	1
38		GND	Ground	1
39		GND	Ground	
40	CML-I	Tx6n	Transmitter Inverted Data Input	
41	CML-I	Tx6p	Transmitter Non-Inverted Data Input	1
42		GND	Ground	
43	CML-I	Tx8n	Transmitter Inverted Data Input	
44	CML-I	Tx8p	Transmitter Non-Inverted Data Input	
45		GND	Ground	1
46		Reserved	For future use	3
47		VS1	Module Vendor Specific 1	3
48		VccRx1	3.3V Power Supply	2
49		VS2	Module Vendor Specific 2	3
50		VS3	Module Vendor Specific 3	3
51		GND	Ground	1
52	CML-0	Rx7p	Receiver Non-Inverted Data Output	
53	CML-0	Rx7n	Receiver Inverted Data Output	
54		GND	Ground	1
55	CML-0	Rx5p	Receiver Non-Inverted Data Output	
56	CML-0	Rx5n	Receiver Inverted Data Output	
57		GND	Ground	1
58		GND	Ground	1
59	CML-0	Rx6n	Receiver Inverted Data Output	
60	CML-0	Rx6p	Receiver Non-Inverted Data Output	
61		GND	Ground	1
62	CML-0	Rx8n	Receiver Inverted Data Output	
63	CML-0	Rx8p	Receiver Non-Inverted Data Output	

64		GND	Ground	1
65		NC	No Connect	3
66		Reserved	For future Use	3
67		VccTx1	3.3V Power Supply	2
68		Vcc2	3.3V Power Supply	2
69		Reserved	For future Use	3
70		GND	Ground	1
71	CML-I	Tx7p	Transmitter Non-Inverted Data Input	
72	CML-I	Tx7n	Transmitter Inverted Data Input	
73		GND	Ground	1
74	CML-I	Tx5p	Transmitter Non-Inverted Data Input	
75	CML-I	Tx5n	Transmitter Inverted Data Input	
76		GND	Ground	1

**Notes:**

1. QSFP-DD uses common ground (GND) for all signals and supply (power). All are common within the QSFP-DD module and all module voltages are referenced to this potential unless otherwise noted. Connect these directly to the host board signal-common ground plane.
2. VccRx, VccRx 1, Vcc1, Vcc2, VccTx and VccTx 1 shall be applied concurrently. Requirements defined for the host side of the Host Card Edge Connector are listed in Table 6. VccRx, VccRx 1, Vcc1, Vcc2, VccTx and VccTx1 may be internally connected within the module in any combination. The connector Vcc pins are each rated for a maximum current of 1000mA.
3. All Vendor Specific, Reserved and No Connect pins may be terminated with 50 ohms to ground on the host. Pad 65 (No Connect) shall be left unconnected within the module. Vendor specific and Reserved pads shall have an impedance to GND that is greater than 10kOhms and less than 100pF.
4. Plug Sequence specifies the mating sequence of the host connector and module. The sequence is 1A, 2A, 3A, 1B, 2B, 3B. (see Figure 2 for pad locations) Contact sequence A will make, then break contact with additional QSFP-DD pads. Sequence 1A, 1B will then occur simultaneously, followed by 2A, 2B, followed by 3A,3B.

## 2-Wires EEPROM Interface

The QSFP-DD passive cable EEPROM is compliant with CMIS3.0 specification. Each connector contains a 256 bytes EEPROM at device address A0(h). The information for addresses 0 to 255 is listed below, see table 3. This information can be tailored to any customer request. Any address can be altered to display customer specific information.

A0h address	Name	Value	Description
0	Identifier	18	Type of Serial Module -- See SFF-8024, 19h:OSFP 8X Pluggable Transceiver
1	Version ID	30	the upper nibble is the whole number part and the lower nibble is the decimal part.Example: 21h indicates version 2. 1.
2	Flat_mem	80	Upper memory flat or paged.0b=Paged memory 1b=Flat memory (only page 00h implemented)
	CLEI present		CLEI code present in upper page 00h

	Reserved		Reserved
	TWI Maximum speed		Indicates maximum two-wire serial speed supported by module 00b=Module supports up to 400KHz 01b=Module supports up to 1 MHz 10b=Reserved 1 1b=Reserved
	Reserved		Reserved
3	Reserved	03	Reserved
	Module state		Current state of Module 001b:Module Low Pwr state(Flat memory passive cable assemblies)
	Interrupt		Digital state of IntL Interrupt output signal 0b=IntL asserted 1b=IntL not asserted (default)
4~7	Bank 0 lane flag	00	Indicates that one or more of the flag bits from bank 0
8	Reserved	00	Reserved
	Module state changed flag		Indicates change of Module state
9~ 13	Module Interrupt Flags	00	Module Interrupt Flags
14~25	Module monitors	00	Module monitors Temperature MSB
26~30	Module Global Controls	00	Force Low Pwr ,Software Reset,Custom
31~36	Module Level Flag Masks	00	Module Level Flag Masks
37~63	Reserved	00	Reserved
64~84	Custom	00	Custom
85	Module Type Encodings	03	00h:Undefined 01h:Optical Interfaces: MMF 02h:Optical interfaces: SMF 03h:Passive Cu 04h:Active Cable 005:Base-T
			1A: 100GBASE-CR4 NRZ 1D:400G CR8 PAM4
86	Module Host Electrical interface codes(ApSel:0001b)	1D	01:Copper cable
87	Module Media interface codes(ApSel:0001b)	01	7-4:Host Lane Count 3-0:Media Lane Count
88	Host/Media Lane Count(ApSel:0001b)	88	code 1:if application is allowed on a given host lane.bits0-7 correspond to host lanes 1-8
89	Lane Assignment(ApSel:0001b)	00	Module Host-Media Interface Advertising Codes
90	Module Host Electrical interface	00	



	<b>codes(ApSel:0010b)</b>		
<b>91</b>	<b>Module Media interface codes(ApSel:0010b)</b>	<b>00</b>	<b>Module Host-Media Interface Advertising Codes</b>
<b>92</b>	<b>Host/Media Lane Count(ApSel:0010b)</b>	<b>00</b>	<b>Module Host-Media Interface Advertising Codes</b>
<b>93</b>	<b>Lane Assignment(ApSel:001 0b)</b>	<b>00</b>	<b>Module Host-Media Interface Advertising Codes</b>
<b>94</b>	<b>Module Host Electrical interface codes(ApSel:0011b)</b>	<b>00</b>	<b>Module Host-Media Interface Advertising Codes</b>
<b>95</b>	<b>Module Media interface codes(ApSel:0011b)</b>	<b>00</b>	<b>Module Host-Media Interface Advertising Codes</b>
<b>96</b>	<b>Host/Media Lane Count(ApSel:0011b)</b>	<b>00</b>	<b>Module Host-Media Interface Advertising Codes</b>
<b>97</b>	<b>Lane Assignment(ApSel:001 1b)</b>	<b>00</b>	<b>Module Host-Media Interface Advertising Codes</b>
<b>98</b>	<b>Module Host Electrical interface codes(ApSel:0100b)</b>	<b>00</b>	<b>Module Host-Media Interface Advertising Codes</b>
<b>99</b>	<b>Module Media interface codes(ApSel:0100b)</b>	<b>00</b>	<b>Module Host-Media Interface Advertising Codes</b>
<b>100</b>	<b>Host/Media Lane Count(ApSel:0100b)</b>	<b>00</b>	<b>Module Host-Media Interface Advertising Codes</b>
<b>101</b>	<b>Lane Assignment(ApSel:010 0b)</b>	<b>00</b>	<b>Module Host-Media Interface Advertising Codes</b>
<b>102</b>	<b>Module Host Electrical interface codes(ApSel:0101b)</b>	<b>00</b>	<b>Module Host-Media Interface Advertising Codes</b>
<b>103</b>	<b>Module Media interface codes(ApSel:0101b)</b>	<b>00</b>	<b>Module Host-Media Interface Advertising Codes</b>
<b>104</b>	<b>Host/Media Lane Count(ApSel:0101b)</b>	<b>00</b>	<b>Module Host-Media Interface Advertising Codes</b>
<b>105</b>	<b>Lane Assignment(ApSel:010 1b)</b>	<b>00</b>	<b>Module Host-Media Interface Advertising Codes</b>
<b>106</b>	<b>Module Host Electrical interface</b>	<b>00</b>	<b>Module Host-Media Interface Advertising Codes</b>



	codes(ApSel:0110b)		
107	Module Media interface codes(ApSel:0110b)	00	Module Host-Media Interface Advertising Codes
108	Host/Media Lane Count(ApSel:0110b)	00	Module Host-Media Interface Advertising Codes
109	Lane Assignment(ApSel:0110b)	00	Module Host-Media Interface Advertising Codes
110	Module Host Electrical interface codes(ApSel:0111b)	00	Module Host-Media Interface Advertising Codes
111	Module Media interface codes(ApSel:0111b)	00	Module Host-Media Interface Advertising Codes
112	Host/Media Lane Count(ApSel:0111b)	00	Module Host-Media Interface Advertising Codes
113	Lane Assignment(ApSel:0111b)	00	Module Host-Media Interface Advertising Codes
114	Module Host Electrical interface codes(ApSel:1000b)	00	Module Host-Media Interface Advertising Codes
115	Module Media interface codes(ApSel:1000b)	00	Module Host-Media Interface Advertising Codes
116	Host/Media Lane Count(ApSel:1000b)	00	Module Host-Media Interface Advertising Codes
117	Lane Assignment(ApSel:1000b)	00	Module Host-Media Interface Advertising Codes
118~ 125	Password Entry and Change	00	Password Entry and Change
126	Bank Select Byte	00	The module shall ignore the Bank Select byte if the Page Select byte is outside of the 10h to 1Fh range (inclusive).In this case the Bank Select byte shall revert to bank 0 and read/write operations shall be to bank 0.
127	Page Select Byte	00	Writing the value of a non-supported page shall not be accepted by the module. In such cases the Page Select byte shall revert to 0 and read/write operations shall be to upper page 00h.
128	Identifier	18	Identifier Type of Module
129~ 144	Vendor name	*	Vendor name(ASCII)

145	Vendor OUI	3C	Vendor IEEE company ID
146		18	
147		A0	
148~ 163	Vendor PN	*	Part number provided by vendor(ASCII)
164	Vendor rev	41	Vendor rev A
166~ 181	Vendor SN	*	Vendor Serial Number(ASCII)
182~ 189	Date code	*	Date code(ASCII)
190~ 199	CLEI code	00	Common Language Equipment Identification code
200	Module Card Power Class	00	000: Power class 1; 001: Power class 2 010: Power class 3; 011: Power class 4 100: Power class 5; 101: Power class 6 1 10: Power class 7; 1 1 1: Power class 8
201	Max Power	06	Maximum power consumption in multiples of 0.25 W rounded up to the next whole multiple of 0.25 W
202	Cable assembly Length Length multiplier field	*	Multiplier for value in bits 5-0. 00 = multiplier of . 1 01 = multiplier of 1 10 = multiplier of 10 1 1 = multiplier of 100
	Cable assembly Length Base Length field		Link length base value. To calculate actual link length use multiplier in bits 7-6.
203	Media connector Type	23	Type of connector present in the module.See SFF-8024 for codes. 23h:Non-separable Connector
204	Copper cable Attenuation 5GHz	*	Passive copper cable attenuation at 5 GHz in 1 dB increments
205	Copper cable Attenuation 7GHz	*	Passive copper cable attenuation at 7 GHz in 1 dB increments
206	Copper cable Attenuation 12.89GHz	*	Passive copper cable attenuation at 12.89 GHz in 1 dB increments
207	Copper cable Attenuation 25.8GHz	*	Passive copper cable attenuation at 25.8 GHz in 1 dB increments
208	Reserved	00	Reserved
209	Reserved	00	Reserved
210	Near end implementation lane 8	00	0b=Lane 8 implemented in near end 1b=Lane 8 not implemented in near end
211	Reserved	02	Reserved
	Implemented lanes in far end		See Table 27 for config code of discrete far end connectors
212	Media interface technology	0A	0A: Copper cable unequalized
213~220	Reserved	00	Reserved
221	Custom	00	Custom

222	Checksum	*	Include bytes 128-221
223~251	User custom info NV	00	User custom info NV
252~255	User custom info NV	00	User custom info NV

## Bulk Cable Characteristics

The structure of the cable is shown as the figure , the characteristics of the bulk cable are listed below.

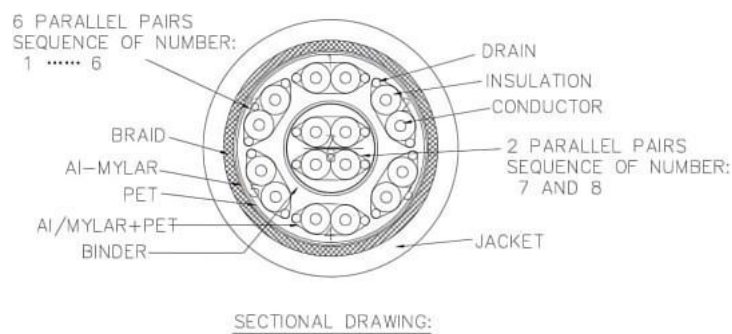

1. Voltage rating: 30V
2. Temperature rating: 0 to 70°C
3. Impedance: Differential mode: 100 +5/-5 ohm @TDR
4. Delay Skew(INTRA-SKEW): 30ps/5m max
5. Signal Twin-ax pair cable: Solid Ag plated copper conductor
6. Braid shielding coverage 85% min
7. Jacket material: PVC

## Qualification Requirement Characteristics

ITEM		REQUIREMENT	TEST CONDITION
Differential Impedance	Cable Impedance	100 + 10/-5 Ω	Rise time of 30ps(at the SMA) (20 % - 80 %).
	Paddle Card Impedance	100 ± 10 Ω	
	Cable Termination Impedance	100 + 10 / - 15 Ω	

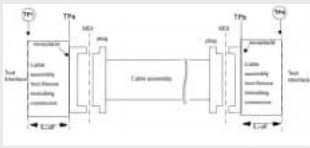
<p><b>Differential(Input/Output) Return loss SDD11/SDD22</b></p>	<p><b>Return_loss(f) &gt;</b></p> $\left\{ \begin{array}{ll} 16.5-2*f & 0.05 \leq f < 4.1 \\ 10.66-14 \log_{10}(f/5.5) & 4.1 \leq f \leq 19 \end{array} \right\}$ <p><b>Where</b> f is the frequency in GHz Return_loss(f) is the return loss at frequency f</p>	<p>10MHz &lt; f &lt; 26.5GHz</p>
<p><b>Differential to common-mode (Input/Output)Return loss SCD11/SCD22</b></p>	<p><b>Return_loss(f) &gt;</b></p> $\left\{ \begin{array}{ll} 22-(20/25.78)*f & 0.01 \leq f < 12.89 \\ 15-(6/25.78)*f & 12.89 \leq f \leq 19 \end{array} \right\}$ <p><b>Where</b> f is the frequency in GHz Return_loss(f) is the Differential to common-mode return loss at frequency f</p>	<p>10MHz &lt; f &lt; 26.5GHz</p>
<p><b>Common-mode to Common-mode (Input/Output)Return loss SCC11/SCC22</b></p>	<p><b>Return_loss(f) &gt; 2dB</b>      0.2 &lt; f &lt; 19</p> <p><b>Where f is the frequency in GHz</b> Return_loss(f) is the common-mode to common-mode return loss at frequency</p>	<p>10MHz &lt; f &lt; 26.5GHz</p>
<p><b>Differential Insertion Loss</b></p>	<p><b>(Differential Insertion Loss Max. For TPa to TPb Including Test fixture )</b></p>	<p>10MHz &lt; f &lt; 19GHz</p>
	<p><b>Passive Cable : - 17. 16dB Min. @ 13.28GHz</b></p> 	<p>10MHz &lt; f &lt; 26.5GHz</p>
<p><b>Differential to common-mode Conversion Loss-Differential Insertion Loss(SCD21- SDD21)</b></p>	<p><b>Conversion_loss(f) - IL(f) &gt;</b></p> <p><b>Where</b> f is the frequency in GHz Conversion_loss(f) is the cable assembly differential to common-mode conversion loss IL(f) is the cable assembly insertion loss</p>	<p>10MHz &lt; f &lt; 26.5GHz</p>
<p><b>ICN</b></p>	<p><b>a is the IL @ 13.28GHz</b> 3 &lt; a &lt; 7.65: 9 mV Max 7.65 &lt; a &lt; 26: 12.75 - 0.49 * a mV Max</p>	<p>10MHz &lt; f &lt; 26.5GHz</p>

## Cable Assembly Characteristics

### QSFP-DD TO QSFP-DD

#### Exploded View

- 1.Bot Back Shell
- 2.PCBA(QDD)
- 3.SUS304 LATCH
- 4.Top Back Shell
- 5.Copper foil
- 6.Pull Tap
- 7.Spring
- 8.Raw Cable
- 9.Lock LATCH
- 10.Rivet

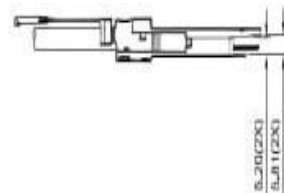
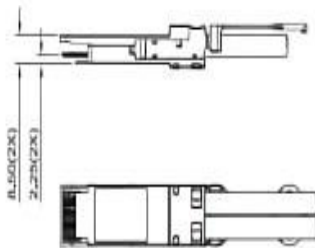
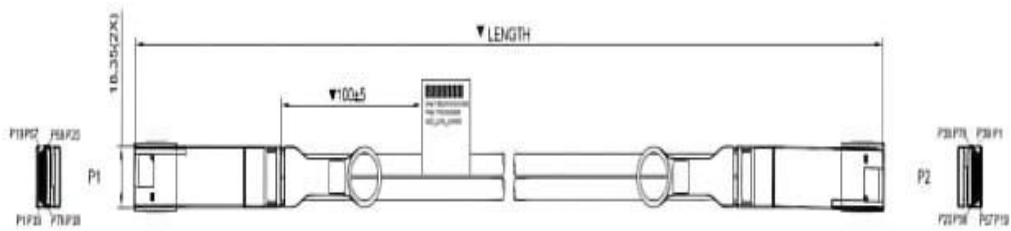
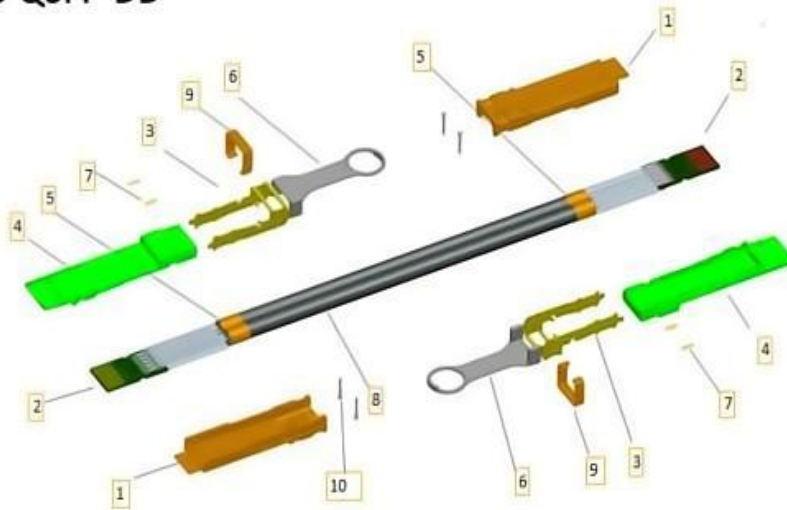

## QSFP-DD 30AWG

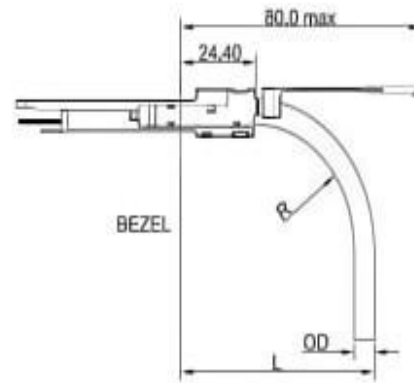
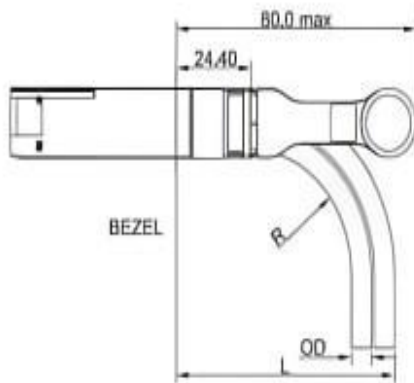

QSFP-DD Horizontal Direction			
CABLE GAUGE	DIAMETER "OD"	MIN.BEND RADIUS "R"	MIN.BEND SPACE "L"
30AWG	6.7MM	33.5MM	72MM

QSFP-DD Vertical Direction			
CABLE GAUGE	DIAMETER "OD"	MIN.BEND RADIUS "R"	MIN.BEND SPACE "L"
30AWG	6.7MM	33.5MM	65MM

## QSFP-DD 28AWG

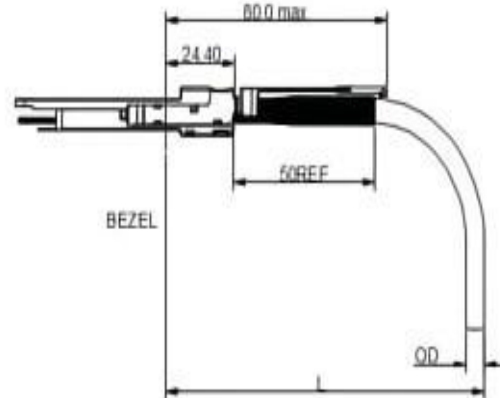
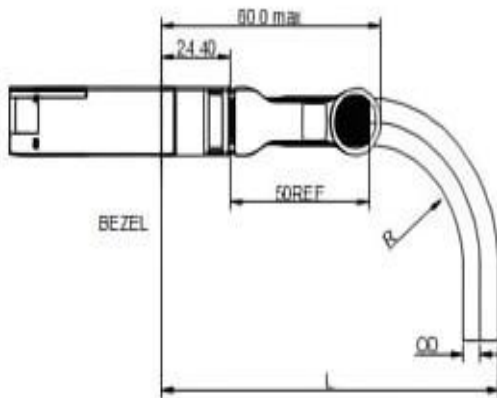

QSFP-DD Horizontal Direction			
CABLE GAUGE	DIAMETER "OD"	MIN BEND RADIUS "R"	MIN BEND SPACE "L"
28AWG	7.0MM	39.5MM	130MM

QSFP-DD Vertical Direction			
CABLE GAUGE	DIAMETER "OD"	MIN BEND RADIUS "R"	MIN BEND SPACE "L"
28AWG	7.0MM	39.5MM	122MM

## Further Information:

---

Web [www.naddod.com](http://www.naddod.com)

Email For order requirements: [sales@naddod.com](mailto:sales@naddod.com)

For cooperation: [agency@naddod.com](mailto:agency@naddod.com)

For customer service: [support@naddod.com](mailto:support@naddod.com)

For other informations: [info@naddod.com](mailto:info@naddod.com)

For technical support: [tech@naddod.com](mailto:tech@naddod.com)

## Disclaimer

---

1. We are committed to continuous product improvement and feature upgrades, and the contents contained in this manual are subject to change without notice.

2. Nothing herein should be construed as constituting an additional warranty.

3. NADDOD assumes no responsibility for the use or reliability of equipment or software not provided by NADDOD.

Copyright © NADDOD.COM All Rights Reserved, 2022