

100Gb/s QSFP28 Active Optical Cable

Features

- Compliant to the industry standard SFF-8636 QSFP28 Transceiver Specification
- Four-channel full-duplex active optical cable
- Hot pluggable
- Low power dissipation: < 3.5W per cable end (< 2.5W with CDRs of)
- Commercial operating case temperature range: 0°C to 70°C
- RoHS-6 compliant (lead-free)
- Metal enclosure for low EMI
- Length available up to 100 meters

Applications

- 100GBASE-SR4 at 25.78125Gbps per lane
- Other optical links

Compliance

- Compliant with SFF-8636
- Compliant with IEEE 802.3bm
- GR-468-CORE
- RoHS Compliance

Absolute Maximum Ratings

Parameter	Symbol	Min.	Typical	Max.	Unit	Note
Supply Voltage	V _{CC3}	-0.5	-	+3.6	V	
Storage Temperature	T _S	- 5	-	+75	°C	
Operating Humidity	RH	+5	-	+85	%	1

Note:

[1] No condensation

Recommended Operating Conditions

Parameter	Symbol	Min.	Typical	Max.	Unit	Note
Operating Case Temperature	T _c	0	-	+70	°C	
Power Supply Voltage	V _{CC}	3.14	3.3	3.47	V	
Power Dissipation	P _d	-	-	2.5	W	1
Bit Rate	BR	10.3125	25.78125	-	Gbps	

Note:

[1] Per terminal

Characteristics

Parameter	Symbol	Min.	Typ.	Max.	Unit	Note
Transmitter						
Differential Data Input Swing	V _{out}	200		1000	mV	
Input Differential Impedance	Z _D	90	100	110	Ω	
Module Select	V _{OL}	V _{EE} -0.3		0.4	V	
Module Unselect	V _{OH}	2.0		V _{CC} +0.3	V	
Low Power Mode	V _{IL}	V _{EE} -0.3		0.8	V	
Normal Operation	V _{IH}	2.0	-	V _{CC} +0.3	V	
Reset	V _{IL}	V _{EE} -0.3		0.8	V	
Normal Operation	V _{IH}	2.0		V _{CC} +0.3	V	
Receiver						
Differential Data Output Swing	V _{in,P-P}	200		1000	mVPP	
Output Differential Impedance	Z _D	90	100	110	Ω	1

ModPrsL	VOL	VEE-0.3	0.4	V	
Interrupt	VOL	VEE-0.3	0.4	V	
Normal Operation	VoH	2.0	VCC+0.3	V	
Bit Error Rate	- BER		E-12		1

Note: PRBS2^31-1 @ 25.78125 Gbps

Recommended Interface

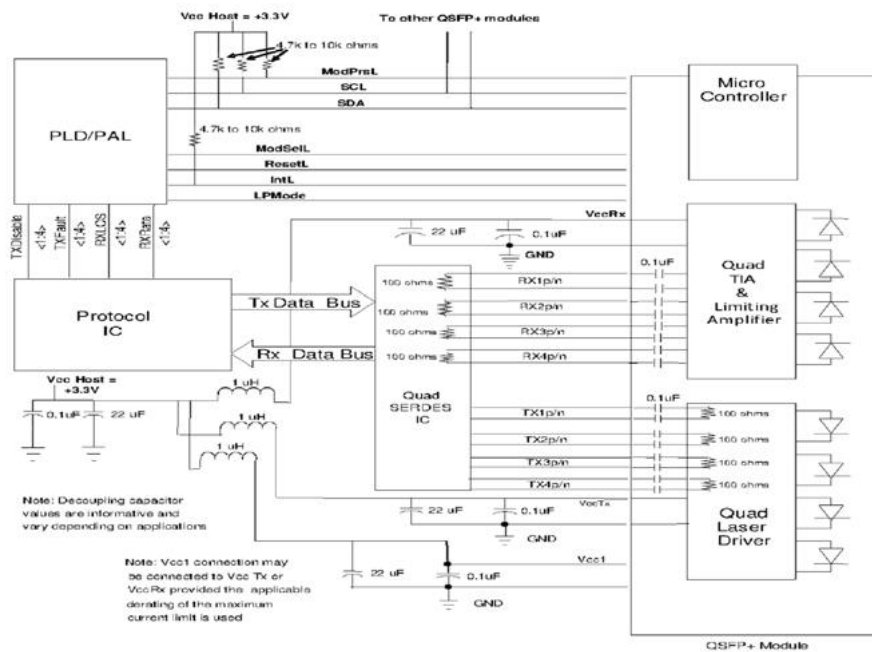

Figure 1 Recommended Interface Circuit

Pin arrangement

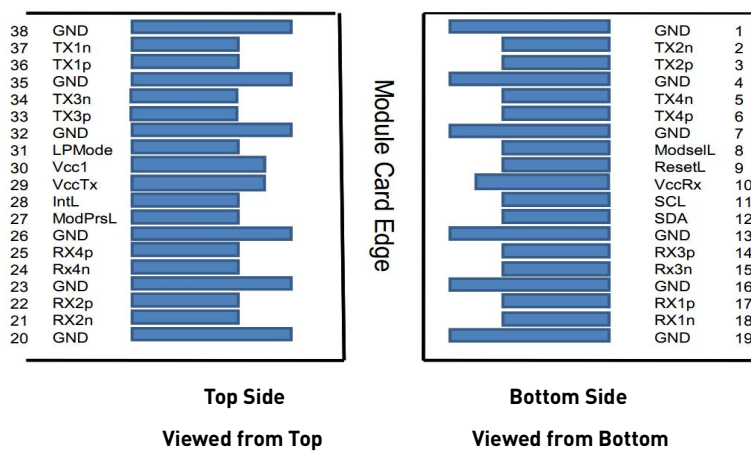

Figure 2 Pin View

Pin Descriptions

Pin	Logic	Symbol	Description	Note
1	G	GND	Ground	1
2	S	Tx2n	Transmitter Inverted Data Input	
3	S	Tx2p	Transmitter Non-Inverted Data Input	
4	G	GND	Ground	1
5	S	Tx4n	Transmitter Inverted Data Input	
6	S	Tx4p	Transmitter Non-Inverted Data Input	
7	G	GND	Ground	
8	IO	ModSelL	Module Select	
9	IO	ResetL	Module Reset	
10	Power	Vcc Rx	+3.3V Power Supply Receiver	2
11	IO	SCL	2-wire serial interface clock	
12	IO	SDA	2-wire serial interface data	
13	G	GND	Ground	
14	S	Rx3p	Receiver Non-Inverted Data Output	
15	S	Rx3n	Receiver Inverted Data Output	
16	G	GND	Ground	1
17	S	Rx1p	Receiver Non-Inverted Data Output	
18	S	Rx1n	Receiver Inverted Data Output	1
19	G	GND	Ground	1
20	G	GND	Ground	
21	S	Rx2n	Receiver Inverted Data Output	
22	S	Rx2p	Receiver Non-Inverted Data Output	
23	G	GND	Ground	
24	S	Rx4n	Receiver Inverted Data Output	
25	S	Rx4p	Receiver Non-Inverted Data Output	
26	G	GND	Ground	1
27	IO	ModPrsL	Module Present	
28	IO	IntL	Interrupt	
29	Power	Vcc Tx	+3.3V Power supply transmitter	2

30	Power	Vcc1	+3.3V Power supply	2
31	IO	LPMode	Low Power Mode	
32	G	GND	Ground	1
33	S	Tx3p	Transmitter Non-Inverted Data Input	
34	S	Tx3n	Transmitter Inverted Data Input	
35	G	GND	Ground	1
36	S	Tx1p	Transmitter Non-Inverted Data Input	
37	S	Tx1n	Transmitter Inverted Data Input	
38	G	GND	Ground	1

Monitoring Specification

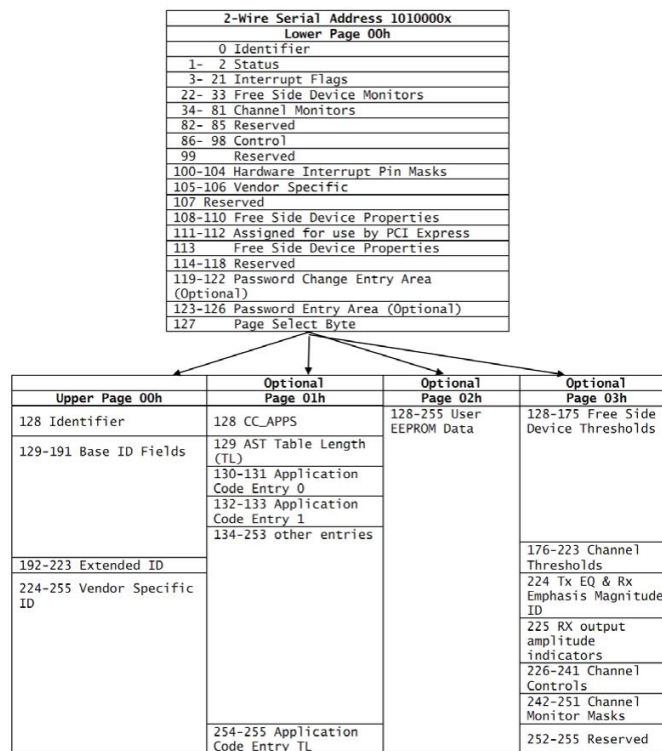

Figure 3 Monitoring Specification

Mechanical

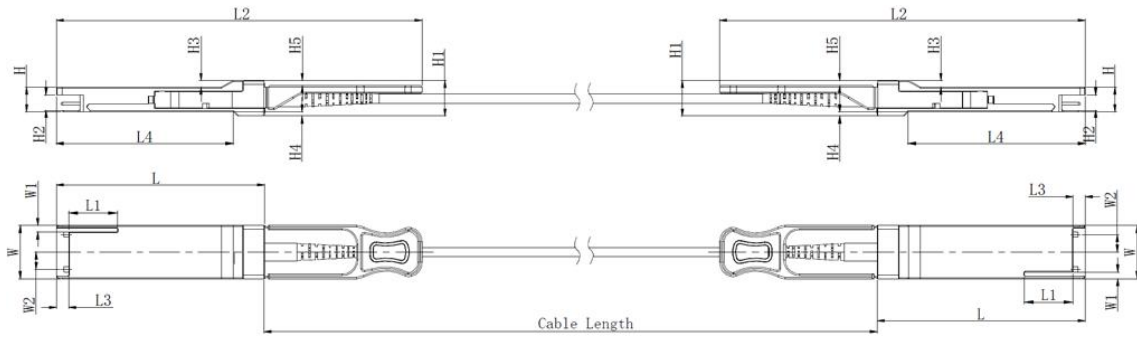

Figure 4 Mechanical Diagram

Unit mm

	L	L1	L2	L3	L4	W	W1	W2	H	H1	H2	H3	H4	H5
Max	72.2	-	128	4.35	61.4	18.45	-	6.2	8.6	12.4	5.35	2.5	1.6	2.0
Type	72.0	-	-	4.20	61.2	18.35	-	-	8.5	12.2	5.2	2.3	1.5	1.8
Min	68.8	16.5	124	4.05	61.0	18.25	2.2	5.8	8.4	12.0	5.05	2.1	1.3	1.6

Cable Length

Parameter	Value	Units
Diameter	3	mm
Minimum bend radius	30	mm
Length tolerance	Length \leq 1 m:	+5 / -0 cm
	1 m \leq length \leq 4.5 m:	+15 / -0 cm
	5 m \leq length \leq 14.5 m:	+30 / -0 cm
	Length $>$ 15.0 m	+2% / -0 m
Cable color	Orange(OM2),Aqua(OM3),Magenta(OM4)	

Warnings

Handling Precautions: This device is susceptible to damage as a result of electrostatic discharge (ESD). A static free environment is highly recommended. Follow guidelines according to proper ESD procedures.

Laser Safety: Radiation emitted by laser devices can be dangerous to human eyes. Avoid eye exposure to direct or indirect radiation.

Further Information:

Web www.naddod.com

Email For order requirements: sales@naddod.com

For cooperation: agency@naddod.com

For customer service: support@naddod.com

For other informations: info@naddod.com

For technical support: tech@naddod.com

Disclaimer

1. We are committed to continuous product improvement and feature upgrades, and the contents contained in this manual are subject to change without notice.

2. Nothing herein should be construed as constituting an additional warranty.

3. NADDOD assumes no responsibility for the use or reliability of equipment or software not provided by NADDOD.

Copyright © NADDOD.COM All Rights Reserved, 2022