

10Gb/s SFP+ SR 300m Optical Transceiver

Features

- Operating data rate 10.3125Gbps
- SFP+ MSA package with duplex LC connector
- Duplex LC connector
- Single +3.3V power supply
- Power dissipation $\leq 1W$
- Differential LVPECL inputs and outputs
- Hot-pluggable capability
- RoHS compliant

Applications

- Switch to Switch interface
- Switched backplane applications
- Router/Server interface
- Other optical transmission systems

Compliance

- SFP MSA
- Compliant to SFP+ Electrical MSA SFF-8431
- Compliant to SFP+ Mechanical MSA SFF-8432
- SFF-8472
- IEEE802.3ae
- RoHS

Description

SFP-10G-SR is a high performance, cost effective modules, which is optimized for 10.3125G Ethernet application, and transmission distance up to 300m on OM3 MMF, The transceiver consists of two sections: The transmitter section incorporates an 850nm VCSEL driver. The receiver section consists of a PIN photo-diode integrated with a transimpedance preamplifier (TIA). The module is hot pluggable into the 20-pin connector.

The high-speed electrical interface is based on low voltage logic, with nominal 100 Ohms differential impedance and AC coupled in the module. The optical output can be disabled by LVTTTL logic high-level input of TX_DIS. Loss of signal (RX_LOS) output is provided to indicate the loss of an input optical signal of receiver.

A serial EEPROM in the transceiver allows the user to access transceiver monitoring and configuration data via the 2-wire SFP Management Interface. This interface uses two single addresses: A0h and A2h. Basic digital diagnostic (DD) data is held in the lower area while specific data is held in a series of tables in the high memory area.

Absolute Maximum Ratings

Table1-Absolute Maximum Ratings				
Parameter	Symbol	Min.	Max.	Unit
Storage Temperature	TS	-40	+85	°C
Supply Voltage	VCC	0	3.6	V
Relative Humidity	RH	5	85	%

Recommended Operating Conditions

Table2-Recommended Operating Conditions						
Parameter	Symbol	Min.	Typical	Max.	Unit	Note
Operating Case Temperature	TC	0		70	°C	
Power Supply Voltage	VCC	3.135	3.3	3.475	V	
	ICC			280	mA	
Power Dissipation	PD			1000	mW	
Data Rate			10.3125		Gbps	
Transmission Distance				300	m	OM3

Optical,Electrical Characteristic

Tested under recommended operating conditions, unless otherwise noted

Table3-Transmitter Operating Characteristic-Optical, Electrical						
Parameter	Symbol	Min.	Typical	Max.	Unit	Note
Center Wavelength	λ_C	840	850	860	nm	
RMS Spectral Width				0.45	nm	
Optical Power for TX DISABLE	Poff			-30	dBm	
Output average power	Pavg	-6.5		-1	dBm	
Optical Modulation Amplitude	OMA		-1.5		dBm	
Extinction Ratio	ER	3			dB	
Relative Intensity Noise	RIN			-128	dB/Hz	
Optical Return Loss Tolerance				12	dB	
Transmitter Dispersion Penalty	TDP			3.9	dB	
Optical Eye Mask	Compliant with IEEE 802.3ae					
Tx Input Diff Voltage	VI	180		700	mV	
Tx Fault	VoL	-0.3		0.4	V	At 0.7mA
	IoH	-50		37.5	uA	
Tx_Disable	VIL	-0.3		0.8	V	
	VIH	2		VCC+0.3	V	

Table4-Receiver Operating Characteristic-Optical, Electrical						
Parameter	Symbol	Min.	Typical	Max.	Unit	Note
Center Wavelength	λ_r	840	850	860	nm	
Receiver Sensitivity	Psens			-9.9	dBm	1
Los Assert	LosA	-30			dBm	
Los Dessert	LosD			-11	dBm	
Los Hysteresis	LosH	0.5			dB	
Overload	Pin	-1			dBm	
Receiver Reflectance				-12	dB	
Operating Data Rate			10.3125		Gbps	
Rx Output Diff Voltage	Vo	300		850	mV	
Rx_LOS	VoL	-0.3		0.4	V	At 0.7mA
	IoH	-50		37.5	uA	2
RS0 and RS1	VIL	-0.3		0.8	V	
	VIH	2		VCC+0.3	V	

Notes:

- [1] Receiver sensitivity is informative. shall be measured with conformance test signal for BER =1x10⁻¹².
- [2] Measured with a 4.7 k Ω load pulled up to Vcc.

Recommended Host Board Power Supply Circuit

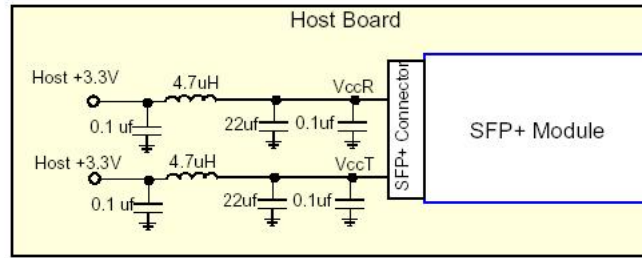

Figure1 Recommended Host Board Power Supply Circuit

Recommended Interface Circuit

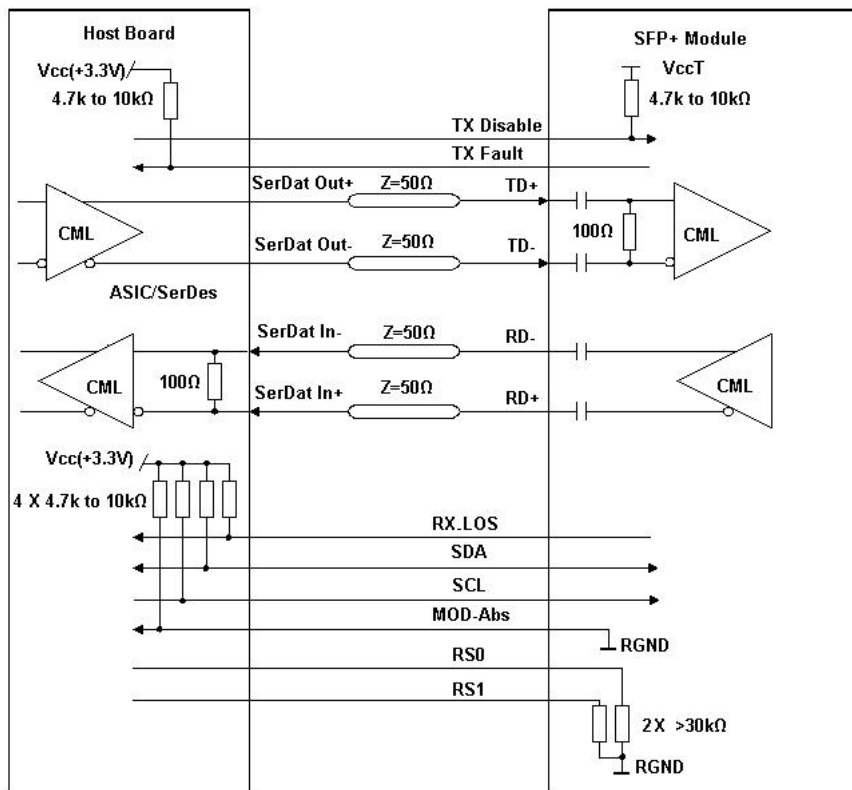

Figure2 Recommended Interface Circuit

Pin-out Definition

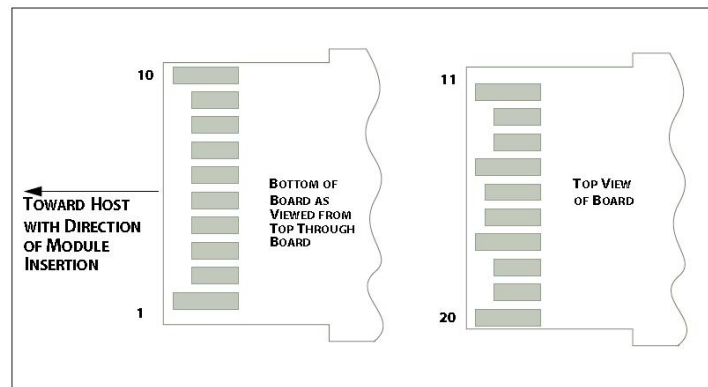

Figure3 Pin view

Pin Function Definitions

Table5-Pin Function Definitions				
Pin	Logic	Symbol	Name/Description	Note
1		VeeT	Module Transmitter Ground	1
2	LVTTL-O	TX_Fault	Module Transmitter Fault	2
3	LVTTL-I	TX_Disable	Transmitter Disable; Turns off transmitter laser output	3
4	LVTTL-I/ O	SDA	2-wire Serial Interface Data Line (Same as MOD-DEF2 as defined in the INF-8074i)	4
5	LVTTL-I/ O	SCL	2-wire Serial Interface Clock (Same as MOD-DEF1 as defined in the INF-8074i)	4
6		MOD_ABS	Module Absent, connected to VeeT or VeeR in the module	5
7	LVTTL-I	RS0	Adaptive multi-rate operation	6
8	LVTTL-O	RX_LOS	Receiver Loss of Signal Indication (In FC designated as RX_LOS, in SONET designated as LOS, and in Ethernet designated at Signal Detect)	2
9	LVTTL-I	RS1	Adaptive multi-rate operation	6
10		VeeR	Module Receiver Ground	1
11		VeeR	Module Receiver Ground	1
12	CML-O	RD-	Receiver Inverted Data Output	
13	CML-O	RD+	Receiver Non-Inverted Data Output	
14		VeeR	Module Receiver Ground	1
15		VccR	Module Receiver 3.3 V Supply	
16		VccT	Module Transmitter 3.3 V Supply	
17		VeeT	Module Transmitter Ground	1
18	CML-I	TD+	Transmitter Non-Inverted Data Input	
19	CML-I	TD-	Transmitter Inverted Data Input	
20		VeeT	Module Transmitter Ground	1

- [1]The module signal ground pins, VeeR and VeeT, shall be isolated from the module case.
- [2]This pin is an open collector/drain output pin and shall be pulled up with 4.7kΩ-10kΩ to Host_Vcc on the host board. [3] Pull ups can be connected to multiple power supplies, however the host board design shall ensure that no module pin has voltage exceeding module VccT/R + 0.5V.
- [3]This pin is an open collector/drain input pin and shall be pulled up with 4.7kΩ-10kΩ to VccT in the module.
- [4]See SFF-8431 4.2 2-wire Electrical Specifications.
- [5]This pin shall be pulled up with 4.7kΩ-10kΩ to Host_Vcc on the host board.
- [6]Connect with 30kΩ load pulled down to GND in the module.

Monitoring Specification

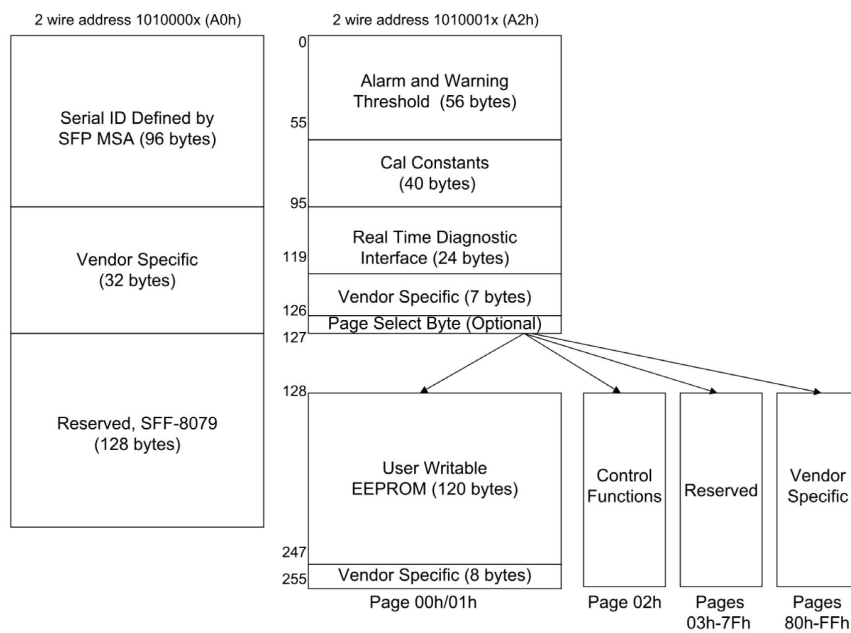
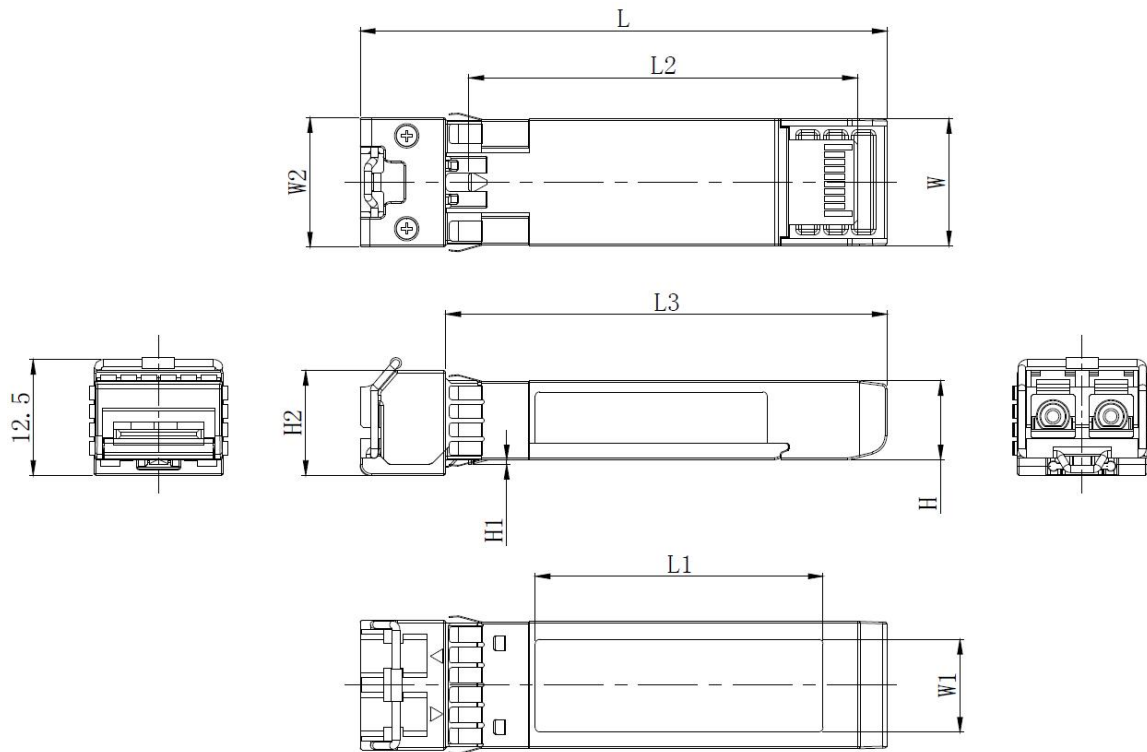

Figure4 Memory map

Mechanical



Unit: mm

	L	L1	L2	L3	W	W1	W2	H	H1	H2
MAX	56.9	31.2	41.95	47.7	13.8	10.2	14.0	8.6	0.6	11.5
Typical	56.7	31.0	41.80	47.5	13.7	10.0	-	8.5	0.5	11.3
MIN	56.5	30.8	41.65	47.3	13.5	9.8	-	8.4	0.4	11.1

Further Information:

Web www.naddod.com

Email For order requirements: sales@naddod.com

For cooperation: agency@naddod.com

For customer service: support@naddod.com

For other informations: info@naddod.com

For technical support: tech@naddod.com

Disclaimer

1. We are committed to continuous product improvement and feature upgrades, and the contents contained in this manual are subject to change without notice.

2. Nothing herein should be construed as constituting an additional warranty.

3. NADDOD assumes no responsibility for the use or reliability of equipment or software not provided by NADDOD.

Copyright © NADDOD.COM All Rights Reserved, 2022