

10G BIDI XFP TX-1270nm/RX-1330nm 20km Optical Transceiver

Features

- Support 9.95Gb/s to 11.3Gb/s bit rates
- Hot Pluggable XFP footprint
- Single LC for Bi-directional Transmission
- Maximum link length of 20km
- Single 3.3V voltage supply
- Uncooled 1270nm CWDM DFB Laser
- Power dissipation < 1.5W
- No Reference Clock required
- Built-in digital diagnostic functions
- Temperature range 0°C to 70°C
- Very low EMI and excellent ESD protection
- ROHS Compliant

Applications

- 10GBASE-LR/LW Ethernet
- SONET OC-192/SDH STM-64
- 1200-SM-LL-L 10G Fibre Channel

Compliance

- IEEE 802.3ae 10GBASE-LR
- XFP MSA

Description

The XFP-10G-U20-23 transceivers are compliant with the current XFP Multi-Source Agreement (MSA) Specification. They comply with 10-Gigabit Ethernet 10GBASE-LR/LW per IEEE 802.3ae, SONET OC-192 /SDH STM-64 and 10G Fibre Channel 1200-SM-LL-L. Digital diagnostics functions are available via a 2-wire serial interface, as specified in the XFP MSA.

Absolute Maximum Ratings

Table1-Absolute Maximum Ratings					
Parameter	Symbol	Min.	Max.	Unit	
Storage Temperature Range	T _{ST}	-40	85	°C	
Supply Voltage	V _{CC}	-0.5	4.0	V	

Recommended Operating Environment

Table2-Recommended Operating Environment					
Parameter	Symbol	Min.	Typical	Max.	Unit
Operating Temperature Range	T _c	0		70	°C
Power Supply Voltage	V _{CC}	3.13	3.3	3.45	V
Bit Rate	BR	9.95		11.3	Gb/s
Bit Error Rate	BER			10 ⁻¹²	
Max. Supported Link Length	L			20	km

Optical Characteristics

Table3-Optical Characteristics							
Parameter	Symbol	Min.	Typical	Max.	Unit	Notes	
Transmitter							
Data Rate	B	9.95		11.3	Gbps		
Maximum Launch Power	P _{max}	-5		0	dBm	1	
Center Wavelength	λ	1260	1270	1280	nm		
Spectral Width	Δλ			1	nm		
Side Mode Suppression Ratio	SMSR _{min}	30			dB		
Average Launch Power of OFF Transmitter	P _{OFF}			-30	dBm		
Extinction Ratio	ER	3.5			dB		
Rise/Fall Time (20%-80%)	T _r /T _f			50	ps		
Tx Jitter	T _{xj}	Compliant with each standard requirements					
Optical Eye Mask		IEEE802.3ae					2

Receiver						
Data Rate	BR	9.95		11.3	Gbps	
Center Wavelength	λ_c	1320	1330	1340	nm	
Receiver Sensitivity	RSEN			-14	dBm	2
Maximum Input Power	P _{MAX}	0			dBm	2
Receiver Reflectance	R _{rx}			-27	dB	
LOS	Optical Assert	LOS _A	-30		dBm	
	Optical Dessert	LOS _D		-15	dBm	
LOS Hysteresis	LOS _H	0.5		5	dB	

Notes:

[1] The optical power is launched into SMF.

[2] Measured with a PRBS 2₃₁-1 test pattern @10.3125Gbps BER < 10⁻¹².

Electrical Characteristics

Table4-Electrical Characteristics							
Parameter	Symbol	Min.	Typical	Max.	Unit	Notes	
Supply Voltage	VCC	3.13		3.45	V		
Supply Current	ICC			500	mA		
Module Total Power	P			2.5	W		
Transmitter							
Input Differential Impedance	RIN		100		Ω	1	
Differential Data Input Swing	V _{IN,pp}	150		820	mV		
Transmit Disable Voltage	VD	2		VCC	V		
Transmit Enable Voltage	VEN	GND		GND+0.8	V		
Transmit Disable Assert Time	T _{off}			100	ms		
Tx Enable Assert Time	T _{on}			100	ms		
Receiver							
Differential Data Output Swing	V _{out,pp}	300	500	850	mV		
Output Rise Time	t _{RISE}			35	ps	2	
Output Fall Time	t _{FALL}			35	ps	2	
LOS Fault	V _{LOSFT}	VCC – 0.5		V _{CCHOST}	V	3	
LOS Normal	V _{LOSNR}	GND		GND+0.5	V	3	
Power Supply Rejection	PSR	See Note 4 below					4

Notes:

[1] After internal AC coupling.

[2] 20-80%.

[3] Loss of Signal is open collector to be pulled up with a 4.7k – 10kohm resistor to 3.15 – 3.6V. Logic 0 indicates normal operation; logic 1 indicates no signal detected.

[4] Per Section 2.7.1. in the XFP MSA Specification.

Pin Function Definitions

Table5-Pin Function Definitions

Pin Number	Logic	Symbol	Name/Description	Notes
1		GND	Module Ground	1
2		VEE5	Optional -5.2 Power Supply – Not required	
3	LVTTTL-I	Mod-Desel	Module De-select; When held low allows the module to respond to 2-wire serial interface commands	
4	LVTTTL-0	Interrupt	Interrupt (bar); Indicates presence of an important condition which can be read over the serial 2-wire interface	2
5	LVTTTL-I	TX_DIS	Transmitter Disable; Transmitter laser source turned off	
6		VCC5	+5 Power Supply	
7		GND	Module Ground	1
8		VCC3	+3.3V Power Supply	
9		VCC3	+3.3V Power Supply	
10	LVTTTL-I	SCL	Serial 2-wire interface clock	2
11	LVTTTL-I/O	SDA	Serial 2-wire interface data line	2
12	LVTTTL-0	Mod_Abs	Module Absent; Indicates module is not present. Grounded in the module	2
13	LVTTTL-0	Mod_NR	Module Not Ready	2
14	LVTTTL-0	RX_LOS	Receiver Loss of Signal indicator	2
15		GND	Module Ground	1
16		GND	Module Ground	1
17	CML-0	RD-	Receiver inverted data output	
18	CML-0	RD+	Receiver non-inverted data output	
19		GND	Module Ground	1
20		VCC2	+1.8V Power Supply – Not required	
21	LVTTTL-I	P_Down/RST	Power Down; When high, places the module in the low power stand-by mode and on the falling edge of P_Down initiates a module reset Reset; The falling edge initiates a complete reset of the module including the 2-wire serial interface, equivalent to a power cycle	
22		VCC2	+1.8V Power Supply – Not required	
23		GND	Module Ground	1
24	PECL-I	RefCLK+	Reference Clock non-inverted input, AC coupled on the host board – Not required	3
25	PECL-I	RefCLK-	Reference Clock inverted input, AC coupled on the host board –Not required	3
26		GND	Module Ground	1
27		GND	Module Ground	1
28	CML-I	TD-	Transmitter inverted data input	
29	CML-I	TD+	Transmitter non-inverted data input	

30	GND	Module Ground	1
----	-----	---------------	---

Notes:

- [1] Module circuit ground is isolated from module chassis ground within the module
- [2] Open collector; should be pulled up with 4.7k – 10k ohms on host board to a voltage between 3.15V and 3.45V.
- [3] A Reference Clock input is not required.

Pin Description

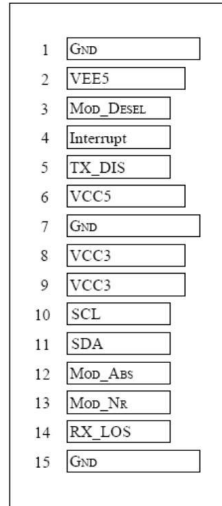

Bottom of Board
(As view through top of board)

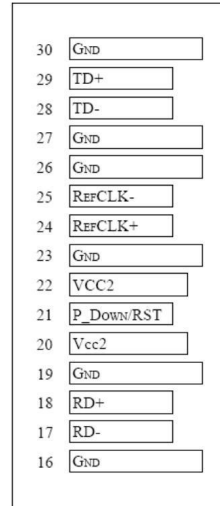

Top of Board

Typical Application Circuit

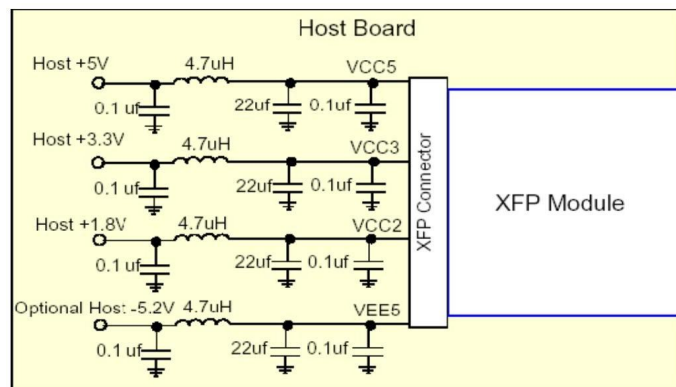

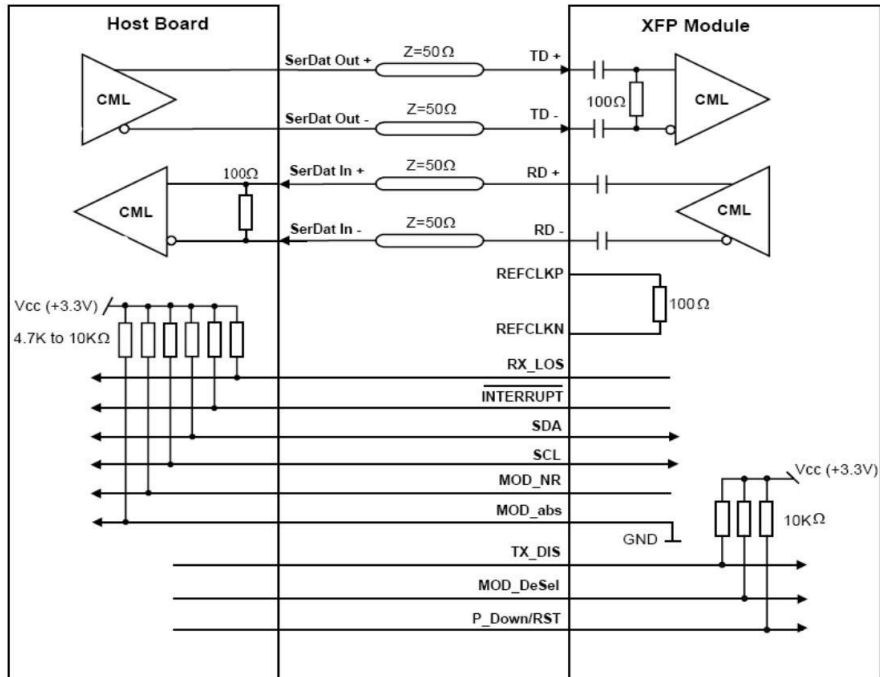
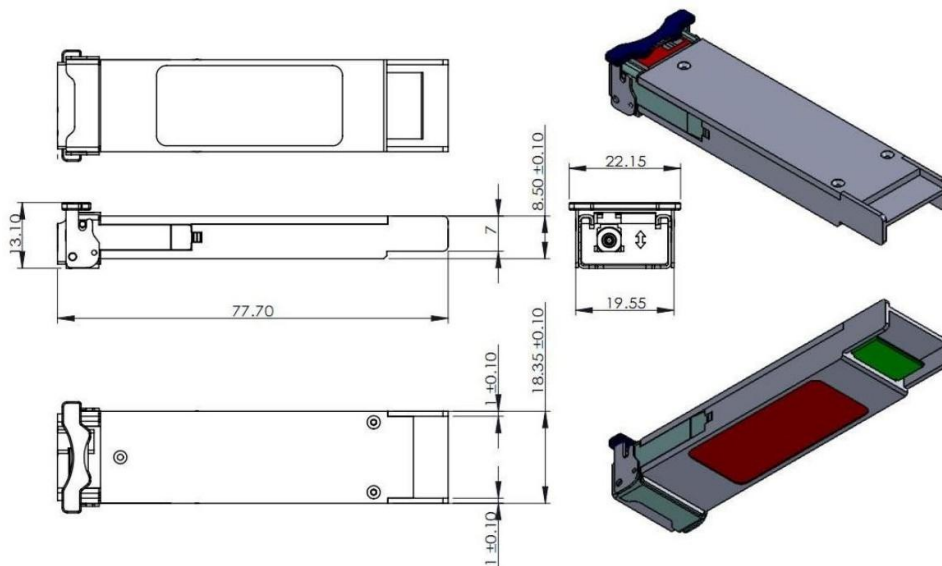

Diagram Mechanical Drawing



Further Information:

Web www.naddod.com

Email For order requirements: sales@naddod.com

For cooperation: agency@naddod.com

For customer service: support@naddod.com

For other informations: info@naddod.com

For technical support: tech@naddod.com

Disclaimer

1. We are committed to continuous product improvement and feature upgrades, and the contents contained in this manual are subject to change without notice.

2. Nothing herein should be construed as constituting an additional warranty.

3. NADDOD assumes no responsibility for the use or reliability of equipment or software not provided by NADDOD.

Copyright © NADDOD.COM All Rights Reserved, 2022