

200Gb/s QSFP56 HDR SR4 850nm 100m MMF Optical Transceiver

Features

- Up to 200Gb/s data rate
- Up to 100m on OM4 and 70m on OM3 multimode fiber at 200Gb/s
- 4x 50Gb/s PAM4 modulation
- Programmable Rx output amplitude and emphasis
- Adaptive Tx input equalizer
- SFF-8665 compliant QSFP56 port
- SFF-8636 DDM compliant
- Single 3.3V power supply
- 4.5W power dissipation
- BER 1E-15 with InfiniBand systems
- QSFP56 power class 5
- Class 1 laser safety
- Hot pluggable
- RoHS compliant
- IEEE 802.3 200GAUI-4 / 200GBASESR4 compliant
- SFF-8636 compliant I²C management interface

Description

Q56-200G-SR4H transceiver is a 4-channel, pluggable, QSFP56, optical transceiver designed for use in 200Gb/s InfiniBand applications. This module incorporates integrated circuit technology in order to provide high performance. The transceiver operates over 4-lane parallel multi-mode fiber (MMF), using a nominal wavelength of 850nm, and is QSFP56 MSA compliant.

The transceiver has a standard SFF-8665 compliant QSFP56 connector on the electrical side towards the host system. The optical interface is composed of four optical channels/fibers in each direction, intended for a parallel multi-mode optical cable via a standard MPO-12 UPC connector. Each channel/fiber operates at signaling rates up to 26.5625GBd. Rigorous production testing ensures the best out-of-the-box installation experience, performance and durability.

The Q56-200G-SR4H transceiver has Digital Diagnostic Monitoring functions for supply voltage, temperature, laser bias current, optical transmit and receive levels with associated warning and alarm thresholds. The Q56-200G-SR4H transceiver will work with a fiber plant as specified in the QSFP MSA standard.

Absolute Maximum Ratings

Parameter	Symbols	Min.	Typical	Max.	Unit	Notes
Storage Temperature	TSTG	-40		+85	°C	
Operating Relative Humidity (non-condensing)	RH	+5		85	%	1
Supply Voltage	Vcc	-0.3		3.6	V	
Receiver Damage Threshold per Lane	PRDMG	3.4			dBm	
Data input voltage	Vcc	-0.3		3.465	V	
Control input voltage	Vcc	-0.3		4.0	V	

Notes:

[1] No condensation

Recommended Operating Conditions

Parameter	Symbols	Min.	Typical	Max.	Unit	Notes
Case Temperature	Tc	0		+70	°C	
Supply Voltage	VCC	3.135	3.3	3.465	V	
Power Dissipation	Pd		4.5	5.0	W	
Supply noise tolerance (10Hz-10MHz)		66			mVpp	
Link Distance with G.652	D			100	m	

Optical interface arrangement

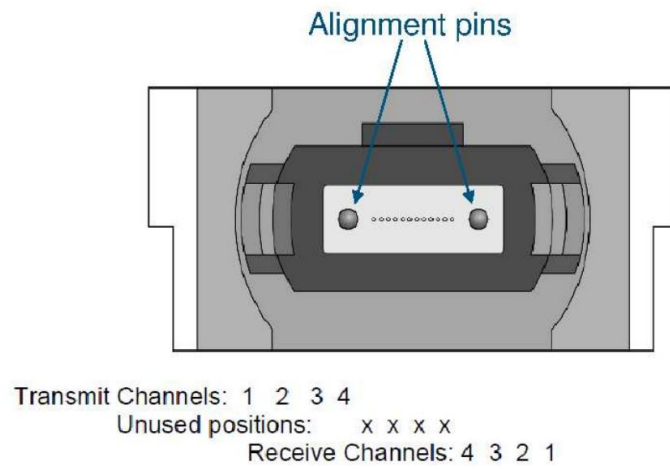

Figure 1 Optical interface arrangement

Mechanical Dimensions

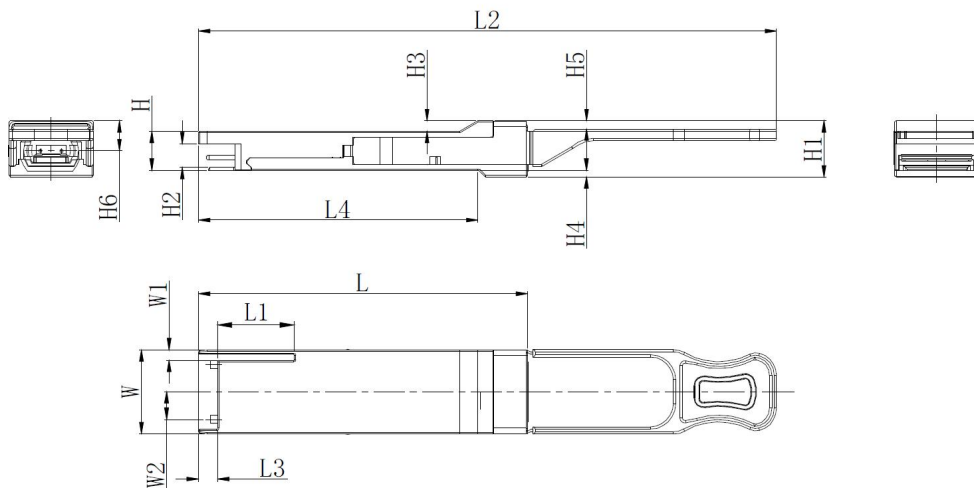

Figure 2 Mechanical Outline

Warnings

Handling Precautions: This device is susceptible to damage as a result of electrostatic discharge (ESD).

A static free environment is highly recommended. Follow guidelines according to proper ESD procedures.

Laser Safety

Radiation emitted by laser devices can be dangerous to human eyes. Avoid eye exposure to direct or indirect radiation.

Further Information:

Web www.naddod.com

Email For order requirements: sales@naddod.com

For cooperation: agency@naddod.com

For customer service: support@naddod.com

For other informations: info@naddod.com

For technical support: tech@naddod.com

Disclaimer

1. We are committed to continuous product improvement and feature upgrades, and the contents contained in this manual are subject to change without notice.

2. Nothing herein should be construed as constituting an additional warranty.

3. NADDOD assumes no responsibility for the use or reliability of equipment or software not provided by NADDOD.

Copyright © NADDOD.COM All Rights Reserved, 2022