

# 100Gb/s QSFP28 EDR Direct Attach Passive Copper Cable

## Features

- Up to 100Gb/s data rate
- SFF-8665 compliant QSFP28
- Operating case temperature 0-70°C
- Single 3.3V supply voltage
- Bit Error Rate (BER) 1E-15 with InfiniBand systems
- Hot pluggable
- RoHS compliant
- LSZH (Low Smoke Zero Halogen) jacket
- LF (Lead Free) HF (Halogen Free) PCB
- SFF-8636 compliant I2C management interface

## Description

QSFP-100G-DACH cables are high speed, cost-effective alternatives to fiber optics in InfiniBand 100Gb/s EDR applications.

The QSFP28 passive copper cables contain four high-speed copper pairs, each operating at data rates of up to 25Gb/s. Each QSFP28 port comprises an EEPROM providing product information, which can be read by the host system

The unique quality passive copper cable solutions provide power-efficient connectivity for short distance interconnects. It enables higher port bandwidth, density and configurability at a low cost and reduced power requirement in the data centers.

Rigorous cable production testing ensures best out-of-the-box installation experience, performance and durability.

## Absolute Maximum Ratings

Parameter	Min.	Max.	Units
Supply voltage	-0.3	3.6	V
Data input voltage	-0.3	3.6	V
Control input voltage	-0.3	3.6	V
Storage temperature	-40	85	°C

## Operational Specifications

Parameter	Min.	Typical	Max.	Units
Supply voltage (Vcc)	3.135	3.3	3.465	V
Power consumption			0.1	W
Operating case temperature	0		70	°C
Operating relative humidity	5		85	%

## Electrical Specifications

Parameter	Min.	Typical	Max.	Units
Characteristic impedance	90	100	110	Ω
Propagation delay (informative)			4.5	ns/m

## Cable Mechanical Specifications

**Table4-Cable Mechanical Specifications**

OPN	AWG	Length (m)	Single Cable Diameter	Minimum Bend Radius	Length Tolerance
QSFP-100G-CU0-5H	30	0.5	7.1 ± 0.35mm	Single bend: 35.5mm Repetitive and assembly bend: 71mm	±25mm
QSFP-100G-CU1H		1			
QSFP-100G-CU1-5H		1.5			
QSFP-100G-CU2H		2			
QSFP-100G-CU2-5H	26	2.5	9.4 ± 0.4mm	Single bend: 47mm Repetitive and assembly bend: 94mm	±50mm
QSFP-100G-CU3H		3			
QSFP-100G-CU4H		4			
QSFP-100G-CU5H		5			

Note 1. The minimum assembly bending radius (close to the connector) is 10x the cable's outer diameter. The repeated bend (far from the connector) is also 10x the cable's outer diameter. The single bend (far from the connector) is 5x the cable's outer diameter

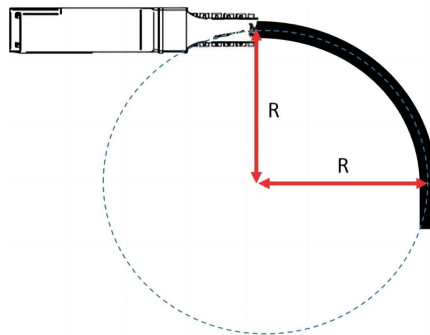

Figure 1. Assembly Bending Radius

## Part Numbers and Descriptions

**Table5-Part Numbers and Descriptions**

Part Number	Description
QSFP-100G-CU0-5H	Passive Copper cable, IB EDR, up to 100Gb/s, QSFP28, 0.5m, Black, 30AWG
QSFP-100G-CU1H	Passive Copper cable, IB EDR, up to 100Gb/s, QSFP28, 1m, Black, 30AWG
QSFP-100G-CU1-5H	Passive Copper cable, IB EDR, up to 100Gb/s, QSFP28, 1.5m, Black, 30AWG
QSFP-100G-CU2H	Passive Copper cable, IB EDR, up to 100Gb/s, QSFP28, 2m, Black, 30AWG
QSFP-100G-CU2-5H	Passive Copper cable, IB EDR, up to 100Gb/s, QSFP28, 2.5m, Black, 26AWG
QSFP-100G-CU3H	Passive Copper cable, IB EDR, up to 100Gb/s, QSFP28, 3m, Black, 26AWG
QSFP-100G-CU4H	Passive Copper cable, IB EDR, up to 100Gb/s, QSFP28, 4m, Black, 26AWG
QSFP-100G-CU5H	Passive Copper cable, IB EDR, up to 100Gb/s, QSFP28, 5m, Black, 26AWG

Note. See Figure 2 for the cable length definition.

Note 2. xx = reach; yy = wire gauge.

## Mechanical Schematics

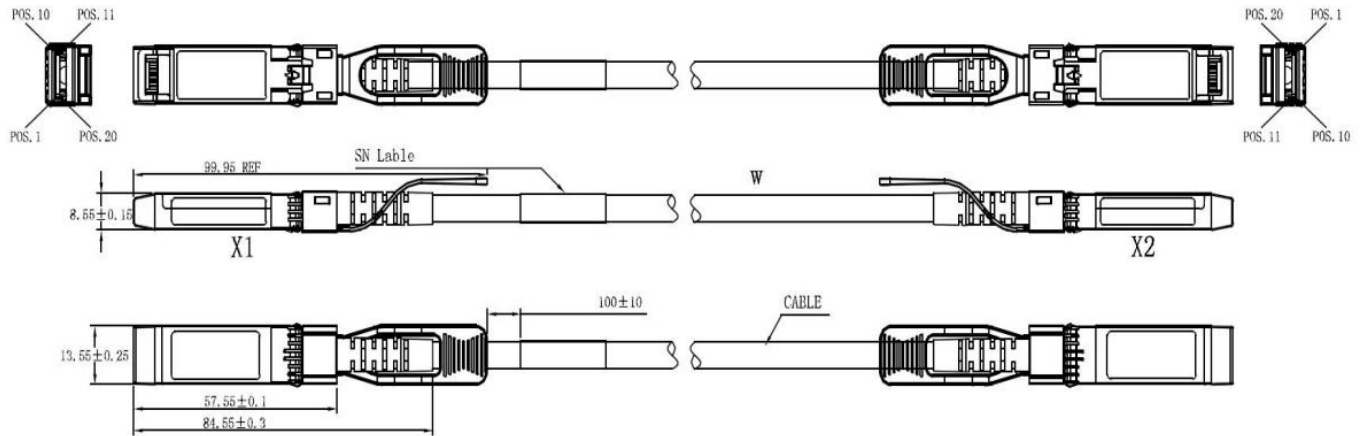

Figure 2. Cable Length Definition

## Warnings

**Handling Precautions:** This device is susceptible to damage as a result of electrostatic discharge (ESD). A static free environment is highly recommended. Follow guidelines according to proper ESD procedures.

**Laser Safety:** Radiation emitted by laser devices can be dangerous to human eyes. Avoid eye exposure to direct or indirect radiation.

## Further Information:

---

Web [www.naddod.com](http://www.naddod.com)

Email For order requirements: [sales@naddod.com](mailto:sales@naddod.com)

For cooperation: [agency@naddod.com](mailto:agency@naddod.com)

For customer service: [support@naddod.com](mailto:support@naddod.com)

For other informations: [info@naddod.com](mailto:info@naddod.com)

For technical support: [tech@naddod.com](mailto:tech@naddod.com)

## Disclaimer

---

1. We are committed to continuous product improvement and feature upgrades, and the contents contained in this manual are subject to change without notice.

2. Nothing herein should be construed as constituting an additional warranty.

3. NADDOD assumes no responsibility for the use or reliability of equipment or software not provided by NADDOD.

Copyright © NADDOD.COM All Rights Reserved, 2022