

1.25Gb/s SFP BIDI TX-1490nm/RX-1310nm10km Optical Transceiver

Features

- Up to 1.25Gbps data links
- 1490nm DFB laser transmitter and PIN photo-detector
- Up to 10km on 9/125µm SMF
- Hot-pluggable SFP footprint
- BIDI LC/UPC type pluggable optical interface
- Low power dissipation
- Metal enclosure, for lower EMI
- RoHS-10 compliant and lead-free
- Support Digital Diagnostic Monitoring interface
- Single +3.3V power supply
- Compliant with SFF-8472
- Case operating temperature: 0 ~ +70°C

Applications

- Switch to Switch interface
- Gigabit Ethernet
- Switched backplane applications
- Router/Server interface
- Other Optical Links

Compliance

- SFP MSA
- SFF-8472
- IEEE802.3z
- RoHS

Description

The SFP-1G-D10-43 transceivers are compatible with the Small Form Factor Pluggable Multi-Sourcing Agreement (MSA). The transceiver consists of five sections: the LD driver, the limiting amplifier, the digital diagnostic monitor, the DFB laser and the PIN photo-detector. The module data link up to 10km in 9/125 μ m single mode fiber.

The optical output can be disabled by a TTL logic high-level input of Tx Disable, and the system also can disable the module via I²C. Tx Fault is provided to indicate that degradation of the laser. Loss of signal (LOS) output is provided to indicate the loss of an input optical signal of receiver or the link status with partner. The system can also get the LOS (or Link)/Disable/Fault information via I²C register access.

Absolute Maximum Ratings

Table1-Absolute Maximum Ratings					
Parameter	Symbols	Min.	Max.	Unit	Notes
Storage Temperature	T _S	-40	85	°C	
Power Supply Voltage	V _{CC}	-0.3	3.6	V	
Relative Humidity (non-condensation)	RH	5	95	%	
Damage Threshold	TH _d	5		dBm	

Recommended Operating Conditions and Power Supply Requirements

Table2-Recommended Operating Conditions and Power Supply Requirements						
Parameter	Symbols	Min.	Typical	Max.	Unit	Notes
Operating Case Temperature	T _{OP}	0		+70	°C	
Power Supply Voltage	V _{CC}	3.135	3.3	3.465	V	
Data Rate			1.25		Gb/s	
Control Input Voltage High		2		V _{CC}	V	
Control Input Voltage Low		0		0.8	V	
Link Distance (SMF)	D			10	km	9/125 μ m

Electrical Characteristic

Tested under recommended operating conditions, unless otherwise noted

Table3-Electrical Characteristic						
Parameter	Symbols	Min.	Typical	Max.	Unit	Notes
Power Consumption	P			0.86	W	

Supply Current	I _{cc}			260	mA	
Transmitter						
Single-ended Input Voltage Tolerance	V _{cc}	-0.3		4.0	V	
Differential Input Voltage Swing	V _{in,pp}	200		2400	mVpp	
Differential Input Impedance	Z _{in}	90	100	110	Ohm	
Transmit Disable Assert Time				5	us	
Transmit Disable Voltage	V _{dis}	V _{cc} -1.3		V _{cc}	V	
Transmit Enable Voltage	V _{en}	V _{ee} -0.3		0.8	V	
Receiver						
Differential Output Voltage Swing	V _{out,pp}	500		900	mVpp	
Differential Output Impedance	Z _{out}	90	100	110	Ohm	
Data output rise/fall time	T _r /T _f		100		ps	20% to 80%
LOS Assert Voltage	V _{losH}	V _{cc} -1.3		V _{cc}	V	
LOS De-assert Voltage	V _{losL}	V _{ee} -0.3		0.8	V	

Optical Characteristic

Table4-Optical Characteristic						
Parameter	Symbols	Min.	Typical	Max.	Unit	Notes
Transmitter						
Center Wavelength	λ_c	1470	1490	1510	nm	
Spectrum Bandwidth(RMS)	σ			1	nm	
Side Mode Suppression Ratio	SMSR	30			dB	
Average Optical Power	PAVG	-9		-3	dBm	1
Optical Extinction Ratio	ER	9			dB	
Transmitter OFF Output Power	POff			-45	dBm	
Transmitter Eye Mask		Compliant with 802.3z(class 1 laser safety)				2
Receiver						
Center Wavelength	λ_c	1260	1310	1360	nm	
Receiver Sensitivity (Average Power)	Sen.			-20	dBm	3
Input Saturation Power (overload)	Psat	-3			dBm	
LOS Assert	LOSA	-36			dB	4
LOS De-assert	LOSD			-21	dBm	4
LOS Hysteresis	LOSH	0.5	2	6	dB	

The following optical characteristics are defined over the Recommended Operating Environment unless otherwise specified.

Notes:

- [1] Measure at 2^7-1 NRZ PRBS pattern
- [2] Transmitter eye mask definition.
- [3] Measured with Light source 1310nm, ER=9dB; BER = $<10^{-12}$ @ PRBS= 2^7-1 NRZ
- [4] When LOS de-asserted, the RX data+/- output is High-level (fixed).

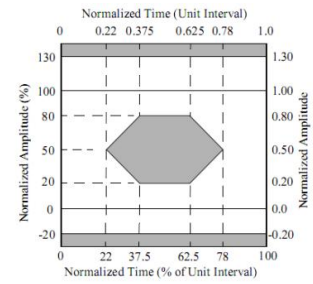

Digital diagnostic Functions

The following digital diagnostic characteristics are defined over the Recommended Operating Environment unless otherwise specified. It is compliant to SFF-8472 Rev10.2 with internal calibration mode. For external calibration mode please contact our sales staff.

Table5-Digital Diagnostic Functions					
Parameter	Symbols	Min.	Max.	Unit	Notes
Temperature monitor absolute error	DMI_Temp	-3	3	degC	Over operating temp
Supply voltage monitor absolute error	DMI_VCC	-0.15	0.15	V	Full operating range
RX power monitor absolute error	DMI_RX	-3	3	dB	
Bias current monitor	DMI_bias	-10%	10%	mA	
TX power monitor absolute error	DMI_TX	-3	3	dB	

Pin Description

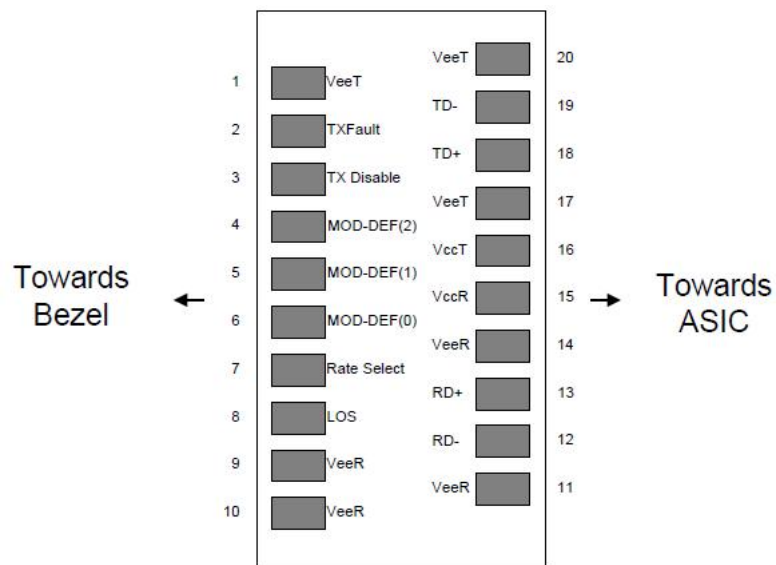

Figure1 Pin view

Pin Function Definitions

Table6-Pin Function Definitions			
PIN	Name	Description	Notes
1	V _{EET}	Transmitter Ground (Common with Receiver Ground)	1
2	T _{FAULT}	Transmitter Fault. Open Drain. Logic "0" indicates normal operation.	
3	T _{DIS}	Transmitter Disable. Laser output disabled on high or open.	2
4	MOD_DEF(2)	Module Definition 2. Data line for Serial ID.	3
5	MOD_DEF(1)	Module Definition 1. Clock line for Serial ID.	3
6	MOD_DEF(0)	Module Definition 0. Grounded within the module.	3
7	Rate Select	No connection required.	4
8	LOS	Loss of Signal indication. Open Drain. Logic "0" indicates normal operation.	5
9	V _{EER}	Receiver Ground (Common with Transmitter Ground)	1
10	V _{EER}	Receiver Ground (Common with Transmitter Ground)	1
11	V _{EER}	Receiver Ground (Common with Transmitter Ground)	1
12	RD-	Receiver Inverted DATA out(CML). AC Coupled	
13	RD+	Receiver Non-inverted DATA out(CML). AC Coupled	
14	V _{EER}	Receiver Ground (Common with Transmitter Ground)	1
15	V _{CCR}	Receiver Power Supply	
16	V _{CCT}	Transmitter Power Supply	
17	V _{EET}	Transmitter Ground (Common with Receiver Ground)	1
18	TD+	Transmitter Non-Inverted DATA in. AC Coupled.	
19	TD-	Transmitter Inverted DATA in. AC Coupled.	
20	V _{EET}	Transmitter Ground (Common with Receiver Ground)	1

Notes:

[1] Circuit ground is internally isolated from chassis ground.

[2] Laser output disabled on TDIS > 2.0V or open, enabled on TDIS < 0.8V.

[3] Should be pulled up with 4.7k-10k ohms on host board to a voltage between 2.0V and 3.6V. MOD_DEF (0) pulls line low to indicate module is plugged in.

[4] This is an optional input used to control the receiver bandwidth for compatibility with multiple data rates (most likely Fiber Channel 1x and 2x Rates). If implemented, the input will be internally pulled down with > 30kΩ resistor. The input states are:

1) Low (0 - 0.8V): Reduced Bandwidth

2) (>0.8, <2.0V): Undefined

3) High (2.0 - 3.465V): Full Bandwidth

4) Open: Reduced Bandwidth

[5] LOS is open collector output should be pulled up with 4.7k-10k ohms on host board to a voltage between 2.0V and 3.6V. Logic 0 indicates normal operation; logic 1 indicates loss of signal.

Mechanical Dimensions

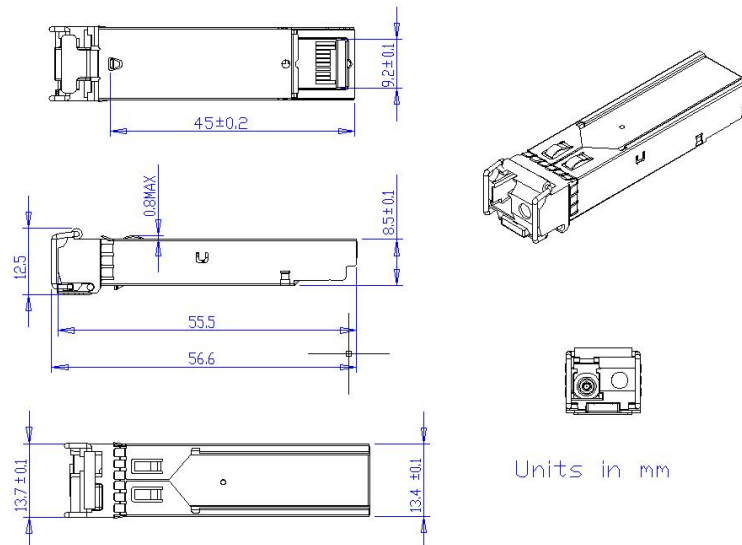

Figure2 Mechanical Outline

Precautions

- This device is susceptible to damage as a result of electrostatic discharge (ESD). A static free environment is highly recommended. Follow guidelines according to proper ESD procedures.
- Radiation emitted by laser devices can be dangerous to human eyes. Avoid eye exposure to direct or indirect radiation.

Further Information:

Web www.naddod.com

Email For order requirements: sales@naddod.com

For cooperation: agency@naddod.com

For customer service: support@naddod.com

For other informations: info@naddod.com

For technical support: tech@naddod.com

Disclaimer

1. We are committed to continuous product improvement and feature upgrades, and the contents contained in this manual are subject to change without notice.
2. Nothing herein should be construed as constituting an additional warranty.
3. NADDOD assumes no responsibility for the use or reliability of equipment or software not provided by NADDOD.

Copyright © NADDOD.COM All Rights