

1.25G/1.25G SFP EPON OLT TX-1490nm/RX-1310nm PX20 20km Optical Transceiver

Features

- Single-mode medium transmission 20km
- Burst Digital Receiving Signal Strength Indication (RSSI)
- Simplex SC connector
- Single +3.3V power supply
- Power dissipation < 1.5W
- Operation case temperature -40~85°C for industrial and 0~70 °C for commercial
- Hot-pluggable capability

Applications

- EPON OLT for a Single Fiber
Bi-directional EPON System
- 1000BASE-PX20 EPON

Compliance

- SFP MSA
- SFF-8472
- IEEE802.3ae
- RoHS
- Class 1 laser safety

Recommended Operating Conditions

Table1-Recommended Operating Conditions

Parameter	Symbol	Min.	Typical	Max.	Unit	Note
Power Supply	V _{CC}	3.135	3.3	3.465	V	
Operating Relative Humidity	RH	5		85	%	
Storage Temperature	T _S	-40		+85	°C	
Operating Case Temp for C-temp	T _S	0		+70	°C	
Operating Case Temp for I-temp	T _S	-40		+85	°C	
Data Rate (TX/RX)			1.25		Gbit/s	

Optical Characteristics

Table2-Optical Characteristics

Parameter	Min.	Typical	Max.	Unit	Note
TX Central Wavelength	1480		1500	nm	
Spectral Width (-20dB)			1	nm	
SMSR	30			dB	
Mean Launched Power (PX20)	2		7	dBm	
Mean Launched Power (TX Off)	7		10	dBm	
Extinction Ratio	9			dB	1
Transmitter and dispersion Penalty (20km G.652)			2.3	dB	
TX Optical Eye Mask	Compliant With IEEE Std 802.3ah™-2004				
Receive Wavelength	1260		1360	nm	
Sensitivity (PX20)			-30	dBm	2
Overload	-6			dBm	
Receiver Threshold Settling Time			250	ns	
RX Dynamic Range	-30		-6	dBm	3
LOS De-assert (PX20)			-31	dBm	
LOS Assert (PX20)	-45			dBm	

SD Hysteresis	0.5		6	dB	
Receiver Reflectance			-12	dB	

Note:

1. Measured with PRBS 2⁷-1 test pattern @1.25Gbps, Low Pass Filter is on.
2. Measured with a PRBS 2⁷-1 test pattern @1.25Gbps and ER=10dB, BER =10⁻¹²
3. Rx Dynamic Range Definition

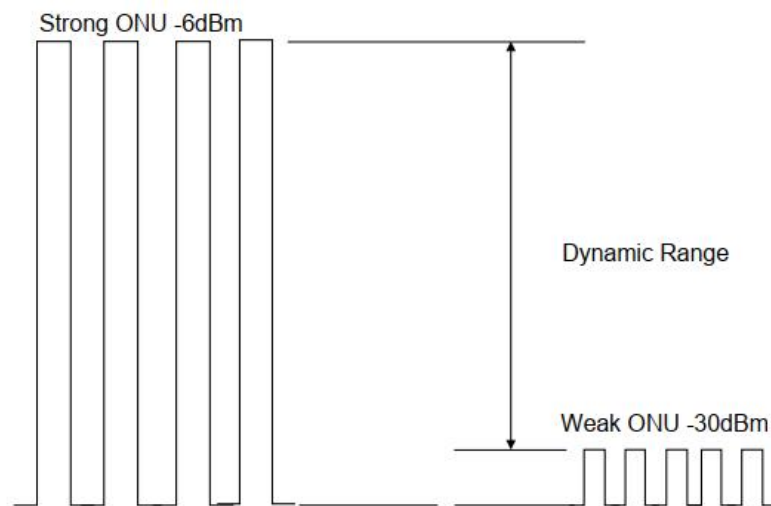

Electrical Characteristics

Table3-Electrical Characteristics					
Parameter	Min.	Typical	Max.	Unit	Note
Power Supply Current			300	mA	
Data Input Differential Swing	200			mV	
Data Differential Impedance	90	100	110	Ω	
TTL Input -Low	0		0.8	V	
TTL Input -High	2.0		V _{cc}	V	
TTL Output -Low	0		0.4	V	
TTL Output -High	2.4		V _{cc}	V	
Data Output Differential Swing	400		1600	mV	
Los Assert Time			500	ns	
Los Deassert Time			500		

RSSI Trigger Time Sequence

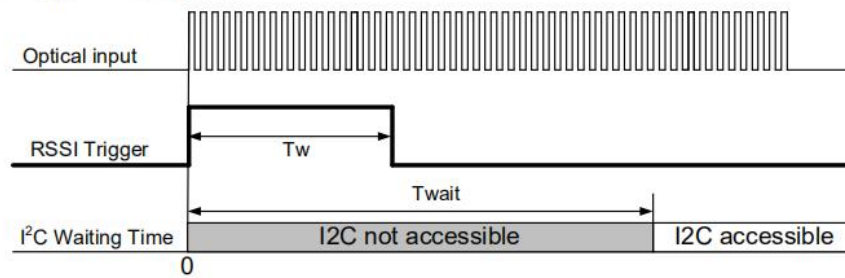

Item	Symbol	Min	Max	unit
Trigger width	T_w	1	1.25	us
I ² C Waiting Time	T_{wait}		500	us

Pin Definition

Table4-Pin Definition

PIN NO.	Name	Level/Logic	Function	Description
1	GNDT	NA	Ground	Transmitter Ground
2	TX_Fault	LVTTTL	TX Fault	TX Fault Alarm, TX Fault State: High; TX Normal State: Low
3	TX_Dis	LVTTTL	Transmitter Enable/Disable	Active High
4	MOD-DEF2	LVTTTL	SDA	I2C clock
5	MOD-DEF1	LVTTTL	SCL	I2C data
6	MOD-DEF0	MOD-DEF0		Module Definition 0, Grounding in SFP
7	RSSI_Trig	LVTTTL		Active High for Sampling
8	LOS	LVTTTL		Loss of Signal. Asserted when light is off
9	GNDR	NA	Ground	Receiver Ground
10	GNDR	NA	Ground	Receiver Ground
11	GNDR	NA	Ground	Receiver Ground
12	RD-	LVPECL	Rx Data-	RX data NOT output, DC coupled output
13	RD+	LVPECL	Rx Data+	RX data output, DC coupled output
14	GNDR	NA	Ground	Receiver Ground
15	VccR	NA	Receiver Power Supply	Rx Power

16	VccT	NA	Transmitter Power Supply	Tx Power
17	GNDT	NA	Ground	Transmitter Ground
18	TD+	LVPECL	Tx Data+	TX data input, internally AC coupled with 100ohm terminated
19	TD-	LVPECL	Tx Data-	TX data NOT input, internally AC coupled with 100ohm terminated
20	GNDT	NA	Ground	Transmitter Ground

Recommended Interface Circuit

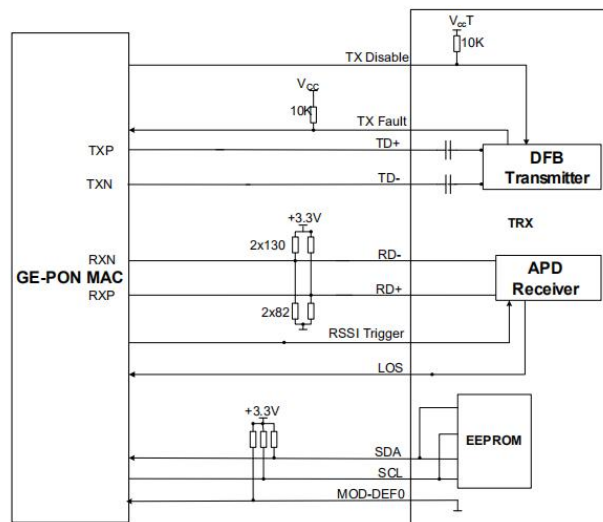

Mechanical Diagram

For detail mechanical information, please refer to the related document of SFP MSA.

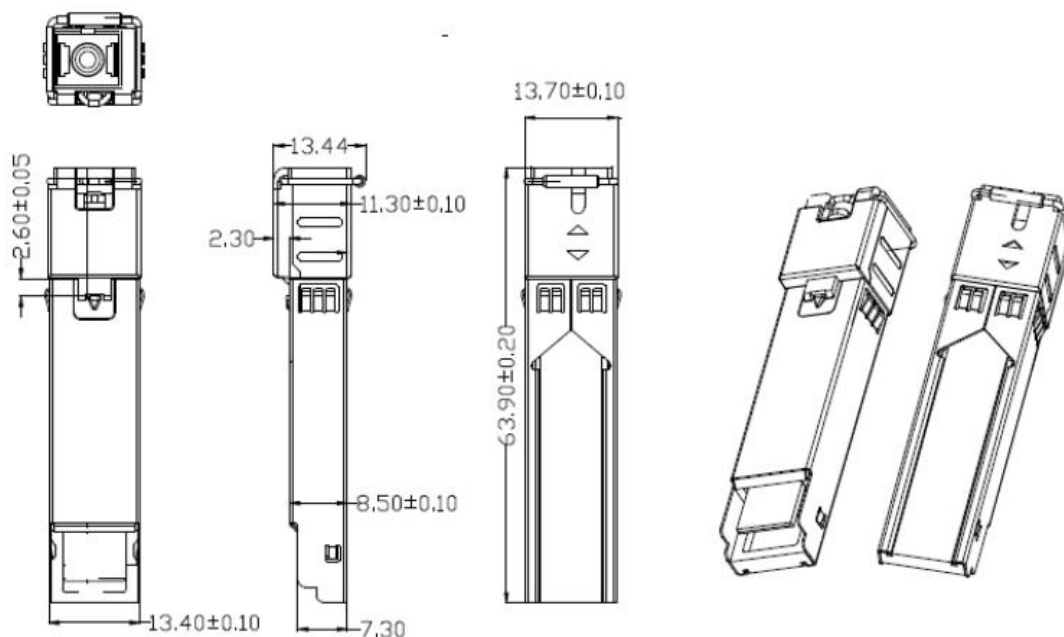

EEPROM Memory Map

The digital diagnostic memory map specific data field define as following. For detail EEPROM information, please refer to the related document of SFF 8472 Rev 12.0.

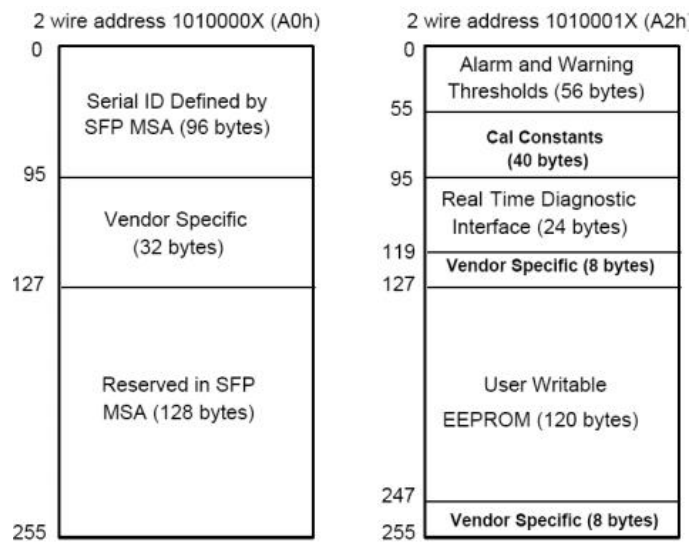

ESD

The SFP+ module and host SFI contacts (High Speed Contacts) shall withstand 1kV electrostatic discharge based on Human Body Model and all host contacts with exception of the SFI contacts (High Speed Contacts) shall withstand 2kV electrostatic discharge based on Human Body Model. The SFP+ module shall meet ESD requirements given in EN61000-4-2, criterion B test specification such that units are subjected to 15kV air discharges during operation and 8kV direct contact discharges to the case per section 2.9 in SFF-8431 REV4.1. However, normal ESD precautions are still required during the handling of this module. This transceiver is shipped in ESD protective packaging. It should be removed from the packaging and handled only in an ESD protected environment.

Laser Safety

This is a Class 1 Laser Product according to IEC 60825-1:2007. This product complies with 21 CFR 1040.10 and 1040.11 except for deviations pursuant to Laser Notice No. 50, dated (June 24, 2007)

Further Information:

Web www.naddod.com

Email For order requirements: sales@naddod.com

For cooperation: agency@naddod.com

For customer service: support@naddod.com

For other informations: info@naddod.com

For technical support: tech@naddod.com

Disclaimer

1. We are committed to continuous product improvement and feature upgrades, and the contents contained in this manual are subject to change without notice.
2. Nothing herein should be construed as constituting an additional warranty.
3. NADDOD assumes no responsibility for the use or reliability of equipment or software not provided by NADDOD.

Copyright © NADDOD.COM All Rights