

2.5G/1.25G SFP GPON OLT TX-1490nm/RX-1310nm Class B+ Optical Transceiver

Produce Features

- Support ITU-T G.984.2 GPON OLT B+ application
 - Single fiber bi-directional data links with symmetric 2.488Gbps Tx and 1.244Gbps Rx
 - 1490nm continuous-mode transmitter with DFB LD
 - 1310nm burst-mode receiver with APD-TIA
 - 2-wire interface for integrated digital diagnostic Monitoring
 - Receiver RESET, Signal Detect, RSSI function indication (RESET, RX_SD, RSSI)
 - SFP package with SC/UPC receptacle optical interface
 - Single +3.3V power supply
 - Operation case temperature 0~70°C
 - RoHS compliance, and Class 1 laser safety
-

Operating Conditions

Table1-Operating Conditions				
Parameter	Unit	Min.	Typical	Max.
Storage Temperature	°C	-40		85
Operating Case Temp	°C	0		70
Operating Relative Humidity	%	5		85
Storage Relative Humidity	%	5		90
Power Supply Voltage	V	3.135	3.3	3.465
Power Supply Current	mA			500
Bit Rate for Tx	Gbps		2.488	
Bit Rate for Rx	Gbps		1.244	

Characteristics

All performance is specified at whole working temperature and conditions

Table2-Characteristics				
Parameter	Unit	Min.	Typical	Max.
Transmitter				
TX Central Wavelength	nm	1480	1490	1500
Spectral Width (-20dB)	nm			1
Side Mode Suppression Ratio (SMSR)	dB	30		
Mean Launched Power (B+)	dBm	1.5		5
Mean Launched Power (TX Off)	dBm			-45
Extinction Ratio	dB	8.2		
Optical Return Loss Tolerance	dB	-15		
Transmitter and dispersion Penalty	dB			1
Transmitter Mask(PRBS2 ²³ - 1@2.488G)		Compliant With ITU-T G.984.2		
Receiver				
Receive Wavelength	nm	1290	1310	1330
Sensitivity (B+) (PRBS223-1@1.244G,ER=10,BER<10 ⁻¹⁰)	dBm			-28
Overload (B+) (PRBS223-1@1.244G,ER=10,BER<10 ⁻¹⁰)	dBm	-8		
Receiver Burst Mode Dynamic Range	dB	15		
SD Assert Level	dBm			-34
SD De-assert Level	dBm	-45		
SD Hysteresis	dB	0.5		6
WDM Filter isolation to 1550nm	dB	38		

WDM Filter isolation to 1650nm	dB	35		
Electrical Interface Characteristics				
Data Input Swing Differential/TX	mV	600	-	1600
Data Output Swing Differential/RX	mV	400		1600
Data Differential Impedance	Ω	90	100	110
LVTTTL Output High	V	2.4		Vcc
LVTTTL Output Low	V	0		0.4
LVTTTL Input High	V	2.0		Vcc+0.3
LVTTTL Input Low	V	0		0.8
Timing Characteristics				
RSSI Trigger Delay (Ttd)	ns	25		
RSSI Trigger Pulse Width (Tw)	ns	500		
Internal I2C Delay (Twait)	us			500

Timing Sequence for RSSI

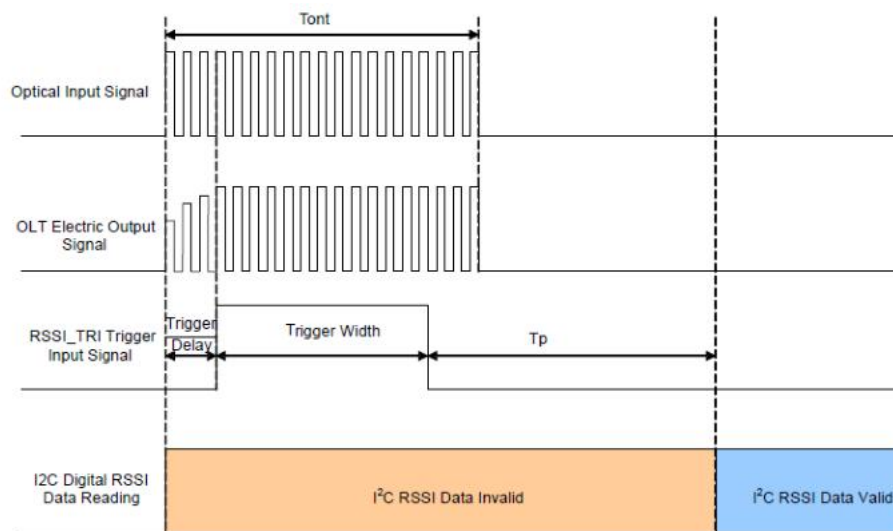
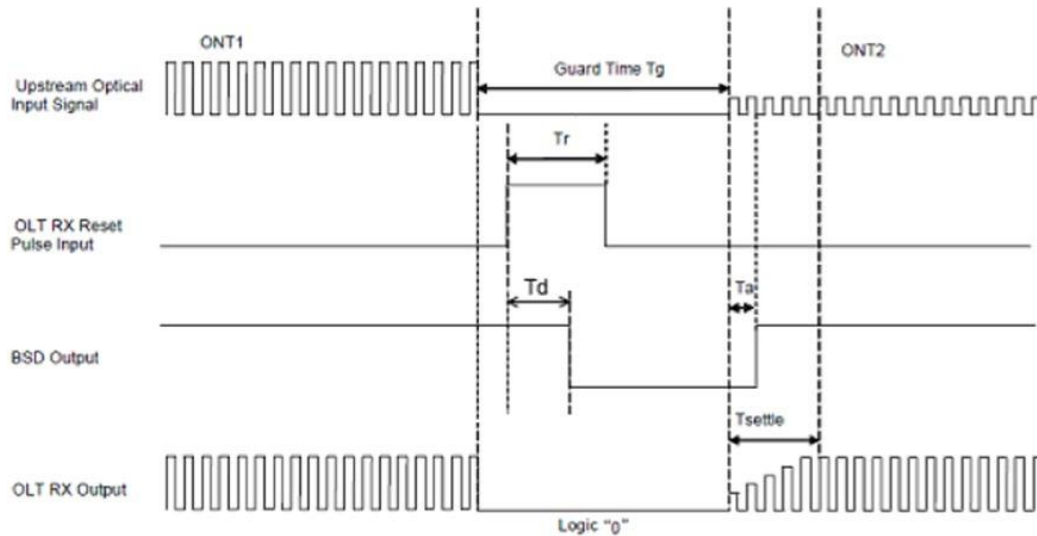

Table3-Timing Sequence for RSSI

Parameter	Unit	Min.	Typical	Max.
RSSI Timing Characteristics				
ONU Package Length (Tont)	ns	300		
RSSI Trigger Delay (Ttd)	ns	0		3000
RSSI Trigger Pulse Width (Tw)	ns	300		Tont - Ttd
Internal I ² C Delay (Tp)	us			500
Input Power Range (B+, Pmon)	dBm	-30		-10
RSSI Monitoring Error	dB		+/-3	

Timing Sequence for Ranging Mode



Timing Sequence for Working Mode

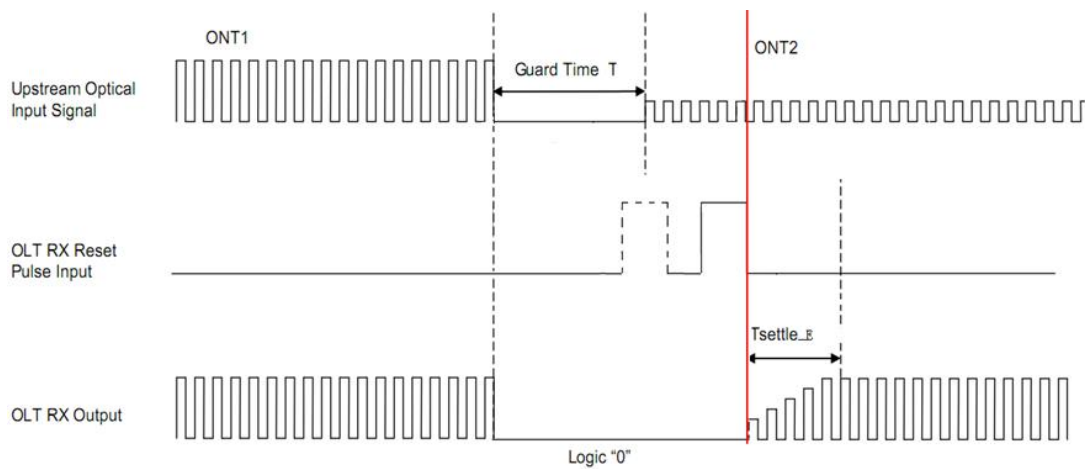

Table4-Timing Sequence for Working Mode

Parameter	Unit	Min.	Typical	Max.
Burst Timing Characteristics				
Guard Time (Tg)	ns		25.6 (4Byte)	
Settling Time (Tsettle)	ns		19.2 (24Bit)	
Settling Time (Tsettle_E)	ns		12.8 (16Bit)	
Reset Pulse Width (Tr)	ns		12.8 (16bit)	
RxSD Assert Time (Ta)	ns			25
RxSD De-assert Time (Td)	ns			10

Note:

[1]. the RxSD signal should be pulled low just followed the Rx Reset, and hold high before the next Rx Reset take place.

Pin Description

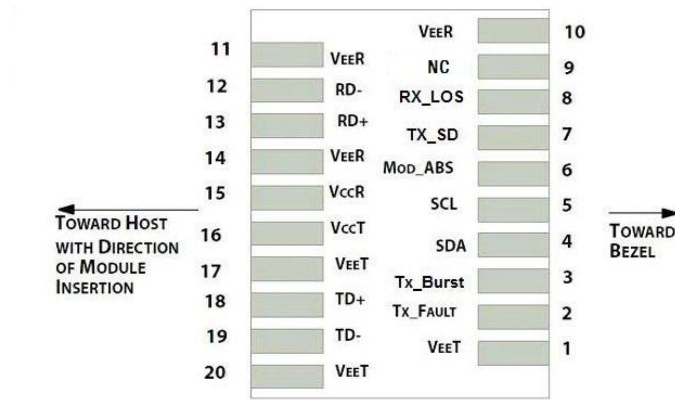

Pin Definitions

Pin	Symbol	Level / Logic	Description
1	VeeT		Module Transmitter Ground
2	Tx_Fault	LVTTTL-0	Module Transmitter Fault
3	Tx_DIS	LVTTTL-I	Laser output is disabled when this pin is asserted high or left unconnected
4	SDA	LVTTTL-I	2-Wire Serial Interface Data Line
5	SCL	LVTTTL-I/O	2-Wire Serial Interface Clock
6	MOD_ABS	LVTTTL-0	Module Absent, connected to ground in the module
7	RX_Reset	LVTTTL-I	Receiver RESET signal
8	RX_SD	LVTTTL-0	Receiver Signal Detected Indication
9	RSSI_TRIG	LVTTTL-I	Receiver RSSI Trigger signal
10	VeeR		Module Receiver Ground
11	VeeR		Module Receiver Ground
12	RD-	LVPECL-0	Receiver Inverted Data Output
13	RD+	LVPECL-0	Receiver Non-Inverted Data Output
14	VeeR		Module Receiver Ground
15	VccR		Module Receiver 3.3V Supply
16	VccT		Module Transmitter 3.3V Supply
17	VeeT		Module Transmitter Ground
18	TD+	LVPECL-I	Transmitter Non-Inverted Data Input
19	TD-	LVPECL-I	Transmitter Inverted Data Input
20	VeeT		Module Transmitter Ground

Recommended Interface Circuit

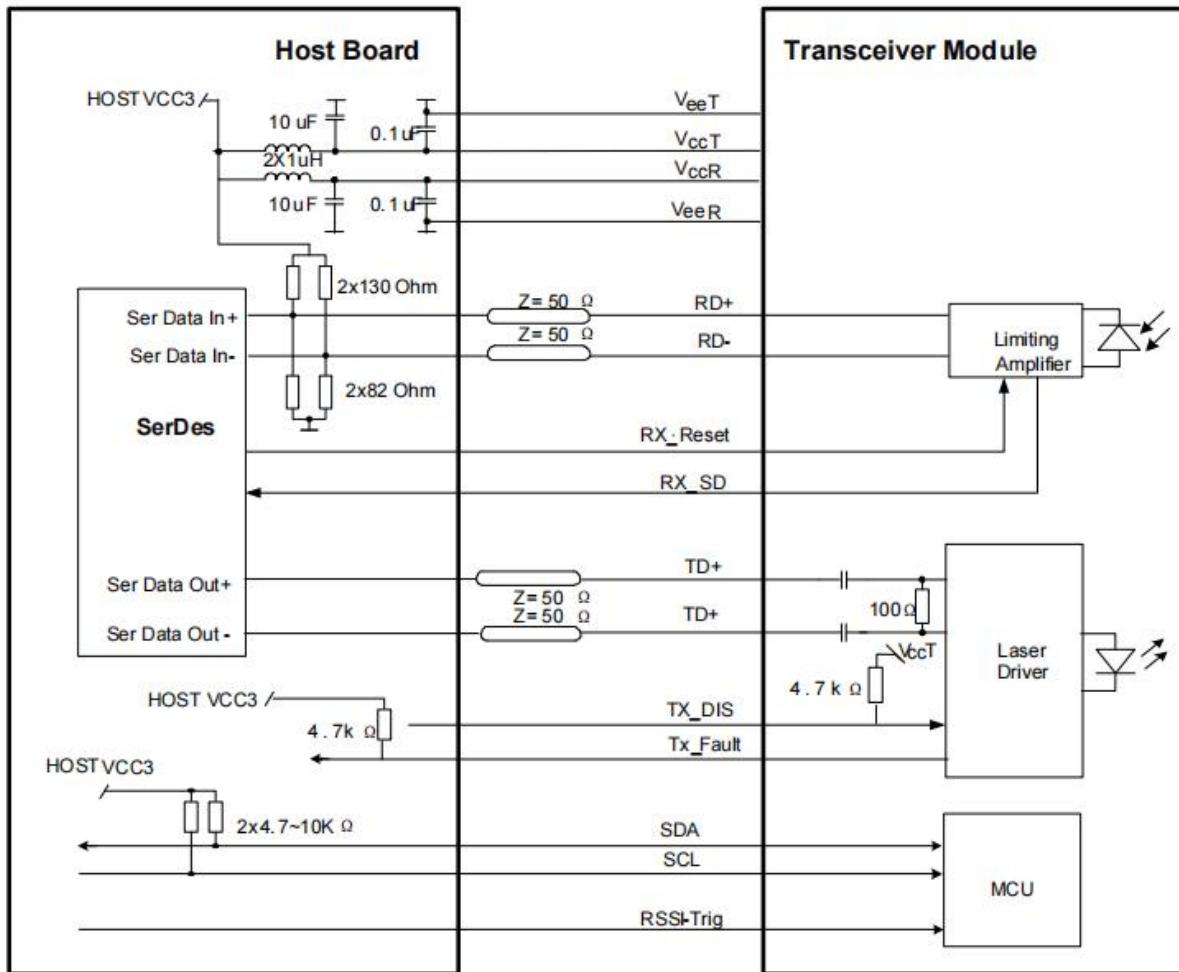

Mechanical Diagram

For detail mechanical information, please refer to the related document of SFP MSA

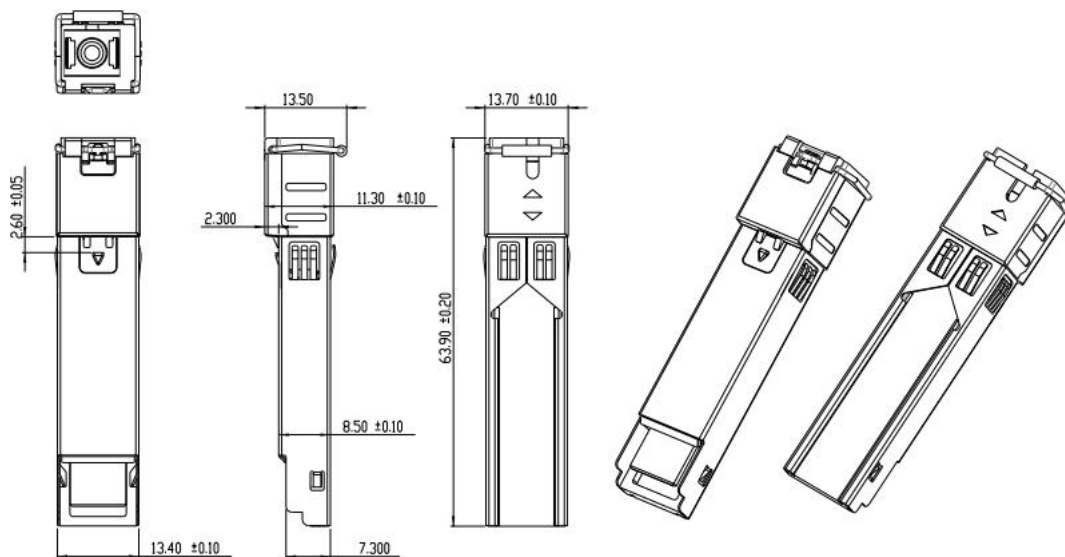

EEPROM Information

The digital diagnostic memory map specific data field define as following. For detail EEPROM information, please refer to the related document of SFF 8472 Rev 12.0.

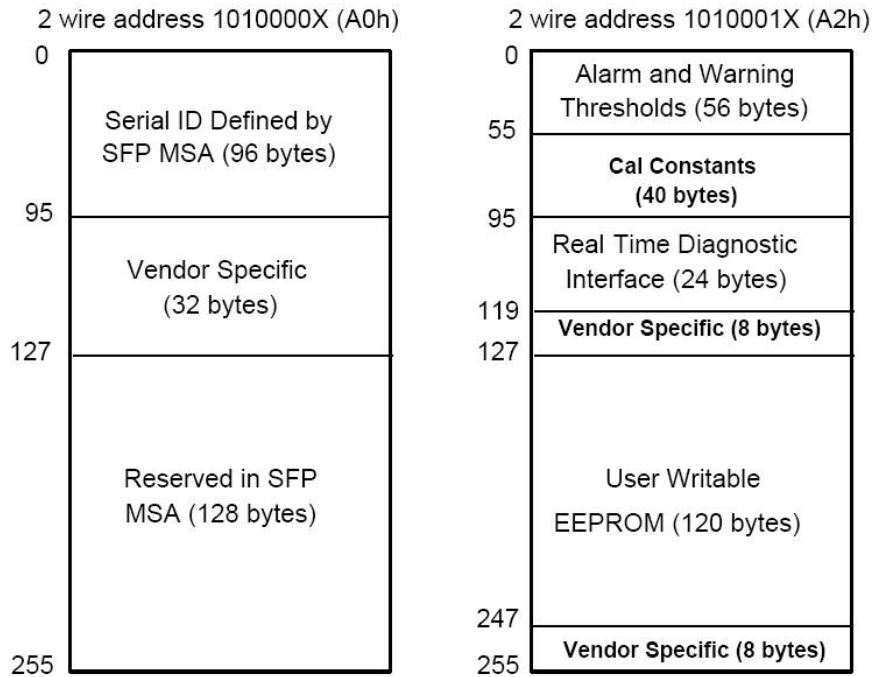

ESD

The SFP+ module and host SFI contacts (High Speed Contacts) shall withstand 1kV electrostatic discharge based on Human Body Model and all host contacts with exception of the SFI contacts (High Speed Contacts) shall withstand 2kV electrostatic discharge based on Human Body Model. The SFP+ module shall meet ESD requirements given in EN61000-4-2, criterion B test specification such that units are subjected to 15kV air discharges during operation and 8kV direct contact discharges to the case per section 2.9 in SFF-8431 REV4.1. However, normal ESD precautions are still required during the handling of this module. This transceiver is shipped in ESD protective packaging. It should be removed from the packaging and handled only in an ESD protected environment.

Laser Safety

This is a Class 1 Laser Product according to IEC 60825-1:2007. This product complies with 21 CFR 1040.10 and 1040.11 except for deviations pursuant to Laser Notice No. 50, dated (June 24, 2007)

Further Information:

Web www.naddod.com

Email For order requirements: sales@naddod.com

For cooperation: agency@naddod.com

For customer service: support@naddod.com

For other informations: info@naddod.com

For technical support: tech@naddod.com

Disclaimer

1. We are committed to continuous product improvement and feature upgrades, and the contents contained in this manual are subject to change without notice.
2. Nothing herein should be construed as constituting an additional warranty.
3. NADDOD assumes no responsibility for the use or reliability of equipment or software not provided by NADDOD.

Copyright © NADDOD.COM All Rights